

# VINYL 4-BEAM PERGOLA

## ASSEMBLY INSTRUCTIONS



Shown - 10'x10' Vinyl 4 Beam Pergola

Thank you for purchasing our 4 Beam Deluxe Vinyl Pergola. Depending on the size of the pergola, installation can usually be completed in a day.

**There are a few things you should consider before installation:**

- 1.) Do not store the Pergola components in direct contact with ground concrete, or other moisture wicking surface as this may warp the components.
  
- 2.) The Base for the Pergola must be solid and level. If installing on a concrete slab or on concrete footers, it should be level where the 4 posts will rest. If not, it may be necessary to cut the bottom of the posts so that the tops are all level, or use shims on the bottom of the posts to raise them up. Other than this, there is no cutting of any of the components of your pergola. If you feel that you will need to make any additional cuts, please call before doing so. ***Making cuts without calling first may make installation difficult and may void our warranties.***
  
- 3.) These instructions show connection to asphalt, using a wedge bolt and tap-con screws. Connecting to concrete is by the same method. If connecting to an existing deck, a lag bolt and deck screws will replace the wedge bolt and tap-con screws. If a deck was ordered with the pergola, see the instructions that are added for the deck.
  
- 4.) The 4 Beam Pergola does not give the ability to alter the location of the posts. It is important that they are laid out correctly and double checked for accuracy before permanently attaching to the base.

**COMPONENTS:**

**Wooden Post Inserts; Steel Brackets with wedge bolts; Vinyl sleeves, post base trim included 36" sleeve, and top and bottom trim. Beams with corner braces; top plates; Main Runners; Top Runners; Hardware. Note: Each size pergola will have varying numbers of components. See the parts list that came with the kit.**

**TOOLS NEEDED:**

**Screw Gun, (Heavy duty drill or impact drill if mounting to concrete, ½" masonry bit), Tape measurer, ladder and a level.**

\* If you purchased a Pergola with the Heavy Duty Post Brackets, refer to the additional instruction sheet that will be included in your kit.

## SECTION ONE - POSTS

### Setting up the template:

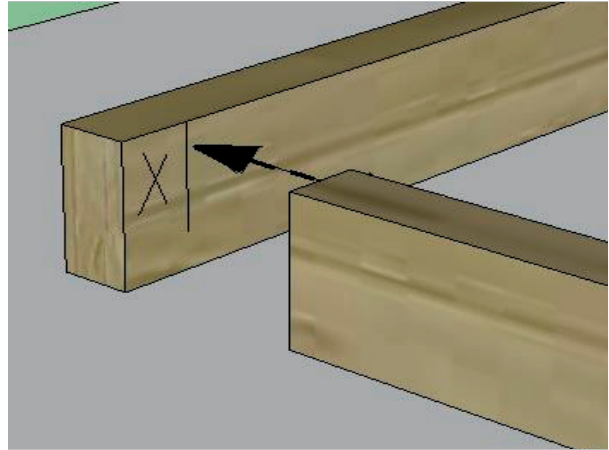
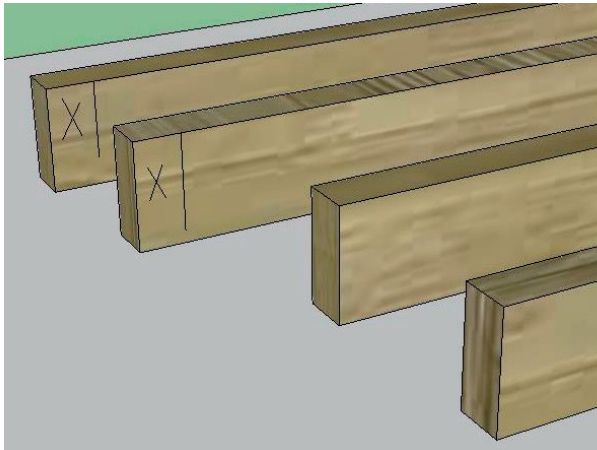

1.) Your pergola kit includes a wooden template that is used to mark your post locations. Notice that two of the 2x4 boards have a marking near the ends. Build a box that will reveal the outside corners of the posts when properly placed.

***NOTE: If you purchased a larger pergola your template will be spliced in the center, just match up the letters and fasten together with (2) screws.***



3.) Connect the corners of the template pieces by driving two 2 ½" screws through the side of the template boards.

2.) Arrange the template pieces so that they are positioned in the exact location of where the pergola will be placed. The boards with the marking on the end will be across from each other. The marks will show where the other boards will be attached to create this box.

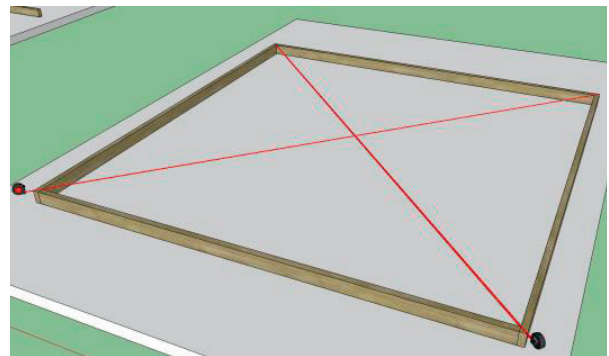

4.) When the template is in position, square the template. Do this by measuring diagonally from one corner to its opposite corner, then measure diagonally between the other two corners. These two dimensions MUST be the same. Adjust the template until the diagonal measurements are identical.



5.) Once the template is "square", mark the post locations using the INSIDE corners of the framed box on a concrete slab with a pencil. After all the post locations are marked on the concrete slab, remove and set the wooden template aside.

#### **Set the Brackets**

6.) The brackets are the 8 L-Brackets in the hardware box. Place them at the outside of the pencil mark, one per corner. Next, drill a hole into your concrete footer or slab. Using a 1/2" masonry bit, drill a hole through the bracket about 1/2" deeper than the length of your anchor bolt. Make sure all of the concrete dust is cleared from the hole, use a vacuum if needed. Add the washer and put the nut on the bolt so the threads are just above the nut. You may need to hit it down with a hammer, you can use a 2x board to hit the top of the bolt so you do not damage the threads on the bolt. Hammer the bolt down until 3/4" of anchor is exposed. Tighten the nut, and the base of the bolt will expand. Once completed, install the rest of the brackets, one per corner. If you purchased a pergola with more than 4 posts, install a bracket for each additional post. On larger structures, there may be (4) L brackets per post.





### Setting the Posts

7.) Place the post on the inside of the pencil mark. Attach the post to the bracket using (5) 2 1/2" screws per bracket. Continue this step until all post are anchored. If your vinyl sleeves are installed on the post already, place the screw on top of the post towards the inside of the pergola so that your header beam will cover it.



### Vinyl Sleeve

8.) Now you are ready to install the vinyl sleeve on all post trim (on some kits the sleeves will be installed already). Slide the vinyl sleeve over each post and fasten to the top of each post with (1) 2 1/2" screw. Keep screw on the inside so the header covers the screw.



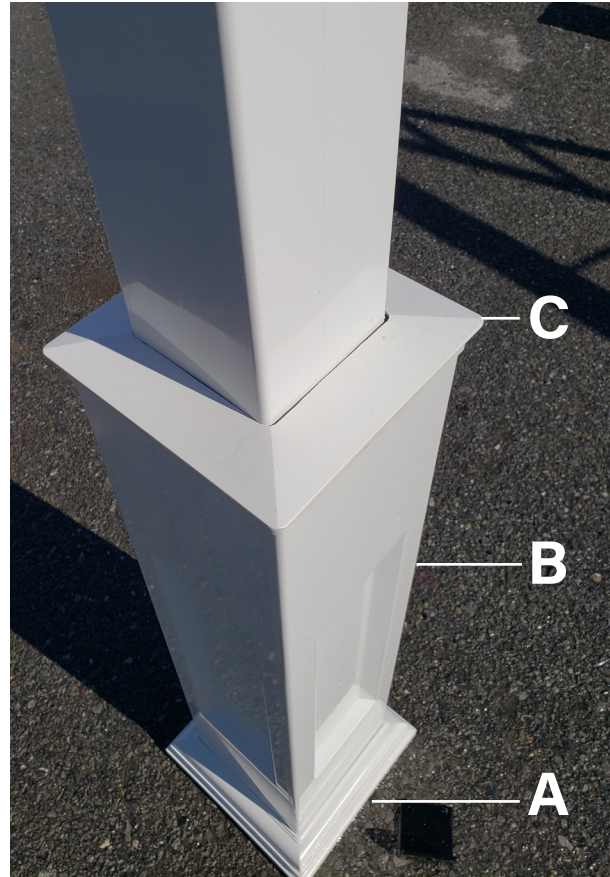
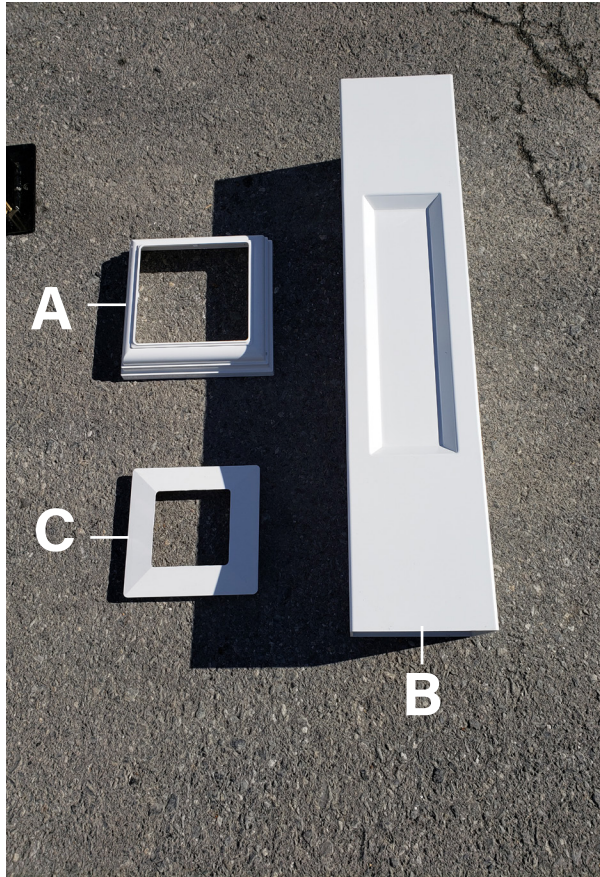

**TIP:** Before proceeding with step 9, double check that the tops of the posts are level. To make sure that they are plumb, you may use a runner, board, line or laser level. Mark the amount that needs to be cut off, lay them down and trim them on the ground. Once the tops are level, proceed to the next step. There is no need to cut the vinyl sleeves.

9.) The deluxe post bases come in boxes with a top and bottom trim. Slide the bottom trim piece (A) onto the base and then slide this over the post. Use a ladder to do this (shown above). Slide the bottom trim down until it rests on the base.

10.) Next, slide the recess panel (B) over the tops of the post. This sleeve will slide inside the base. Next, slide the top trim (C) over the posts and onto the vinyl sleeve (beveled side up). This should be a tight fit. Only slide the top trim part way down the vinyl sleeve.

11.) Raise the vinyl sleeve up until the top of the sleeve is flush with the top of the post. Using one 2 ½" white head screw, attach it so that the sleeve is secure. Place the screw so that it does not face to the outside of the pergola, so to be covered when installing the beams.

12.) Slide the top trim down and snap over the post base. Do this for all the posts. Attach the bottom trim, or let it sit on the patio. If planning to attach the bottom trim, DO NOT do this until the pergola is complete. The posts may need to be moved so it is best to leave the trim unattached until the pergola is complete. Attach using two 1" white headed screws.

## SECTION 2 - BEAMS

---

***When installing beams. Ideally there should be a minimum of 3 people - one to hold each end of the beam in place and one to screw to the posts. Some of the beams can be up to 16' long and weigh over a hundred pounds. Read over the steps in this section before beginning, so as to know what to expect.***

The beams are pre-built and include double 2'x6' beams, with treated pine inserts, double 45 degree corner braces and bottom trim. The 1'x4' vinyl end pieces ("Legs") go against the posts.



13.) Beams have an inside and an outside. Note that there are screws used to keep the double braces together. The screws face towards the inside of the pergola.

14.) Although there is no set pattern, it is probably best to do the shorter beams first to get a feel for how they are done using the lighter beams. Do opposing sides first - not in clockwise or counter clockwise order.



15.) The 1'x4' legs will be used to attach the beams to the posts. Because they can be heavy it is best to attach with (2) screws per side, be sure they are secure enough to let go, and then go back and add the other screws.

It is a good idea to install a couple screws in the legs before lifting them into place. This will make it easier to attach while holding the beams. There are no pre-drilled holes in the legs.

Make sure that the beam is centered in the middle of the post and the top of the beam is flush with the top of the post. Installation is done by lifting the beam until the top of the beam is flush with the top of the post secure with (5) 2 ½" white headed screws on each end, two on either side of the brace and one centered in the bottom. Continue until all the beams are installed.



### **Anchor remaining Posts to Concrete**

16.) Sliding the base up towards the top you can fasten it to the post with a screw to keep it from falling down. Make sure the posts are level and still at the L-shaped pencil mark. Screw the second bracket to the post using (5) 2 ½" screws. It does not matter which side of the post, however we recommend going caddy-corner. Keep in mind you should stay approximately 4" away from the edge of the concrete. Refer back to step 6 for setting the brackets. Once completed remove the screw and place the base in its correct position.





### SECTION 3 - TOP PLATE

The Top Plate is a piece of 1" x 5 1/2" vinyl that is precut to fit on top of the posts and beams. Two of the top plates have markings on them for positioning the runners. Be sure they are facing up and are going the opposite direction as the main runners. Rest all pieces on top of the beams.

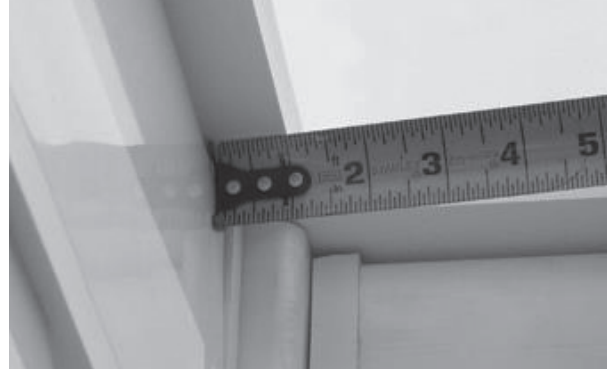

17.) Starting in one corner, position the top plate so that it is corner to corner across the posts. The inside edge of the top plate will overhang the inside of the post by about 1/2". Do not attach the top plate to the posts or beams at this time, and also do not worry about positioning exactly just yet.

18.) Place a 2 1/2" white screw in the side corners of the top plate to attach to the next one, forming a right angle. Do this at all the corners until a box is built.

19.) If the pergola is over 16' there will be two pieces that make up the longer sides of the top plate. Connect them together temporarily with a screw.

20.) After all the corners are attached, check to make sure that the overhangs on all sides are the same. Check the inside overhangs. The top plate will overhang the posts by about 1/2" measuring from the beams. The overhang is about 1" on the inside and the outside. The exact measurement is not important, as long as they are the same on all sides.

21.) Attach to the posts and to the top of the beams with 2 1/2" screws. Attach with (2) screws at the angled cut into the top of the wood posts, and then along the beam, approx. every 24"



## SECTION 4 - MAIN RUNNERS



22.) Notice that the marks on the long sides of the top plate (a line with an X) are spaced the same on both sides. Set a 2'x6' runner up on the frame at one end. Position the first runner over the X, with the edge lined up with the line marked on the top plate.

23.) Next, adjust the runner to get the same overhang measurements on both ends of the runner. Remember the measurement, as this will be used on the rest of the runners making sure that the ends are aligned equally.



24.) When the runner is in the correct position, attach by screwing a 2 ½" white headed screw from the underside of the top plate up into the runner. Pre-drill a pilot hole, at least on the outside runners. Angle the screw as shown at right, being sure to hold down on the runner as you drive the screw in to keep it from moving. Do this for the other ends of the runners.

25.) Set the next runner over the markings and secure in the same manner, making sure that the overhang is the same as in the previous runner. Continue this with each of the runners.

When all of the runners are in place and secured with 2 ½" white head screws. Run a screw from the inside of the pergola, up through the exposed top plate and into the runner as done on the outside. Angle the screw outward slightly.

## SECTION 5 - TOP RUNNERS

26.) The top 1'x1' runners can be added to the tops of the main runners. They are also marked for proper placement and spacing. Similar to the previous step, make sure that the overhang of the top runners are the same on both sides, (As shown below) Secure with 2 ½" white head screws by screwing down through the top runners and into each of the main runners. When fastening top runner to main runner do not set the screw too deep or it will create a dent in the top runner.

Work from one end of the top runner to the other, making sure that the top runner is straight. The top runners are flexible so stay on the markings, or use a straight edge (part of the template) as a guide.

**If you purchased a canopy with your pergola, follow the directions that are included with the canopy.**

Be sure to call your project advisor with any questions.

**ENJOY YOUR NEW 4-BEAM VINYL  
PERGOLA**

