

PAVILION

STICK BUILT VINYL HIP ROOF (NO FLOOR) ASSEMBLY INSTRUCTIONS

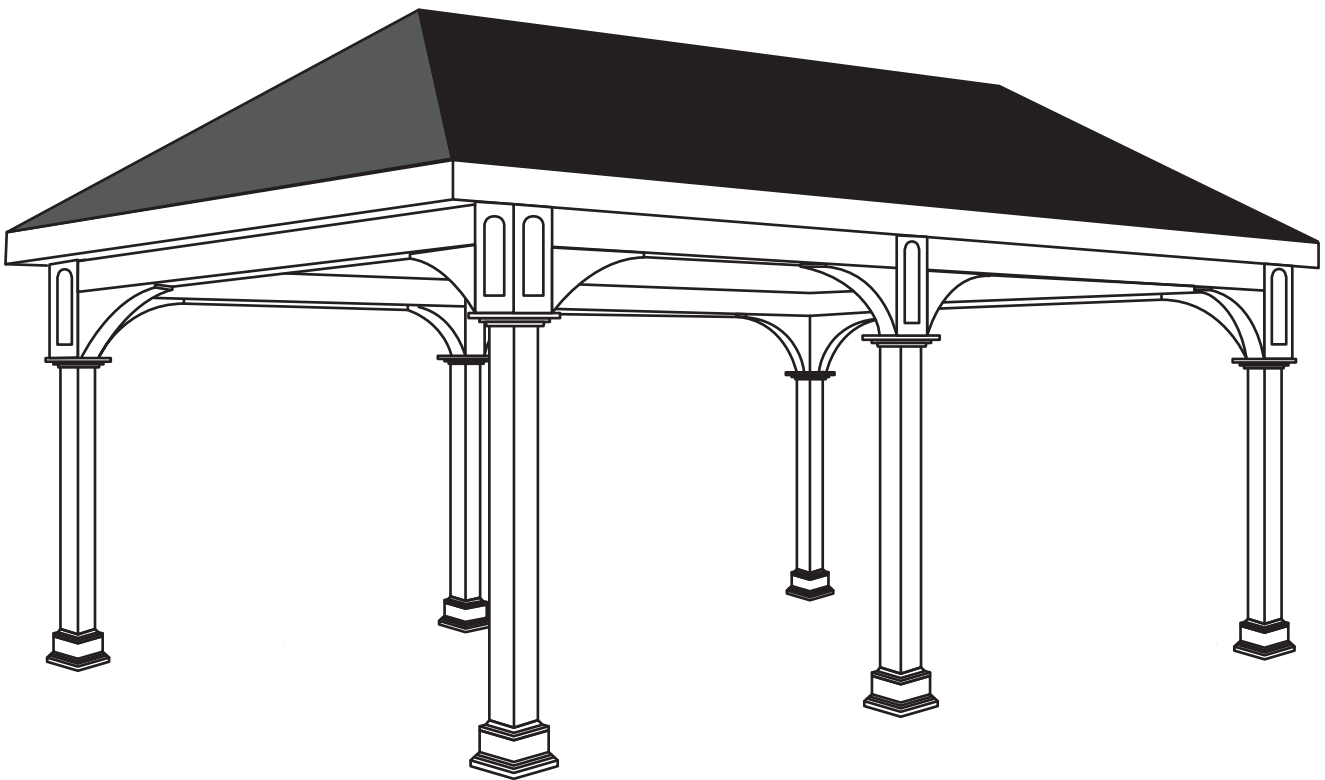

Shown above is a 16' x 24' Hip Roof Pavilion

Thank you for your purchase of a new Hip Roof Pavilion. Depending on the size of your Pavilion, installation can usually be completed in 1 to 2 days. These instructions are meant to serve as a guide for people with a base knowledge of general handyman skills. ***This assembly requires a minimum of four people to complete.***

Before You Begin

Please always check with your local building codes, they will vary from state to state.

The base for the Pavilion must be solid and level. If installing on a concrete slab or on concrete footers, they should be level where the posts will rest. If they are not, it may be necessary to cut the bottom of the posts so that the bottoms are all level. Other than this, no cutting is necessary. If you feel that you will need to make any additional cuts, please contact us before doing so. ***Making cuts without calling first may make installation difficult or void our warranties.***

When connecting to concrete, use wedge bolts, which are included in the kit. If connecting to an existing deck, a lag bolt and deck screws (not included) will replace the wedge bolt.

The Pavilion does not give the ability to alter the location of the posts. It is important that they are laid out correctly and double checked for accuracy before permanently attaching it to the base.

NOTE: These instructions are for building a standard, rectangular pavilion. "Eaves side" references the long side and "gable side" references the short side (See front page image). If your pavilion has custom dimensions with a longer gable side or square dimensions with equal sides, this reference point will need to be adjusted appropriately by the builder during installation. CALL WITH ANY QUESTIONS.

Site Preparation

It is important that the site is properly prepared before beginning assembly. It is imperative that the site be level. There are a few choices when installing this structure, the two most common are to anchor the posts to concrete pad/wood decking or attaching to a concrete footer or two Sonotubes. Sinking the posts into the ground is not recommended unless it is called for by your local building codes.

Anchoring the posts to concrete/wood decking, is the most common method and is also the simplest. Please provide a level concrete or wood decking surface, and then lay out the template on the surface. Mark out the squares where the posts and brackets will go. Line up the markings that were made and this is where to set the posts. Posts cannot be anchored into loose pavers or stone. Customer assumes risk if not anchored into concrete or decking joists. This is the method that will be used for the following instructions:

Please check with the local building codes for the depth required for the footers/concrete slab. Also if using concrete footers make sure that all of the tops of the footers are level with each other before starting to build. Contact your Project Advisor with any questions that you may have.

Tools Needed

Hammer drill, hammer, level, tape measure, C clamps, socket set, ladder, circular saw, scaffolding*

**Scaffolding for square stick built structures only.*

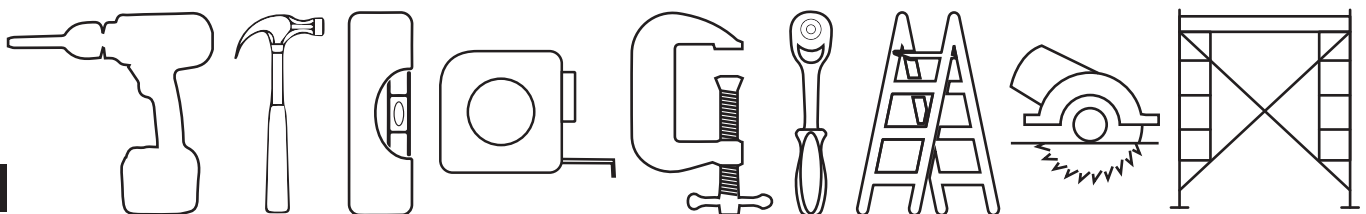

Notes:

*An air-nailer or stapler can be used for rubber or asphalt shingles.
(Air nails and staples not included in the kit.)*

*There will be a parts list sent with the Pavilion. All hardware is included in each Pavilion kit.
The specific hardware will vary depending on the Pavilion. Please see the parts list for details.*

1

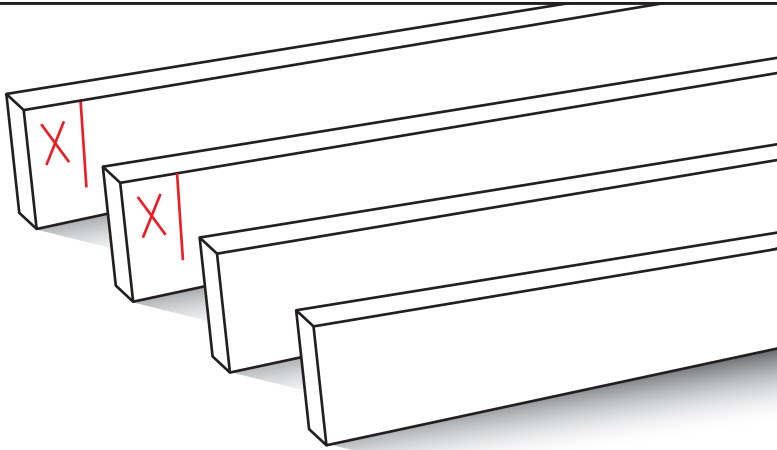

The Pavilion kit includes a wooden template that will be used to mark the post locations. Notice that two of the 2x4 boards have a marking near the ends. Building a box will reveal the outside corners of the posts when properly placed.

Arrange the template pieces so that they are positioned in the exact location of where the Pavilion will be placed. The boards with the marking on the end will be across from each other. The marks will show where the other boards will be attached to create this box.

2

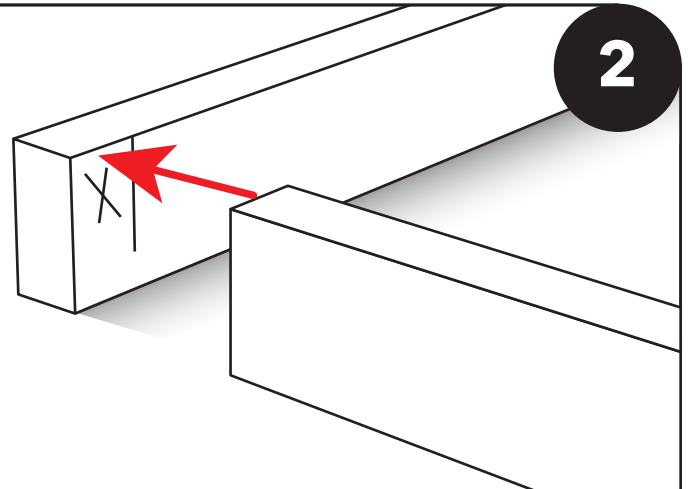

3

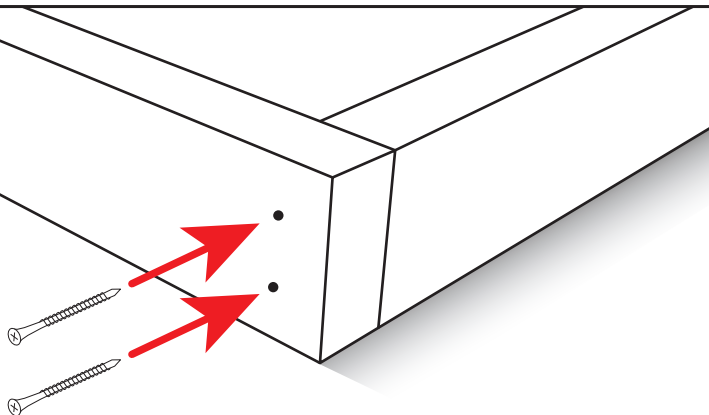

Connect the corners of the template pieces by driving two 2 1/2" screws through the side of the template boards.

3

4

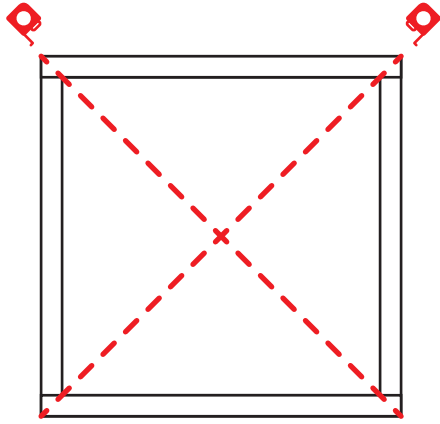

Once the template is in position, square the template. Do this by measuring diagonally from one corner to its opposite corner, then measure diagonally between the other two corners. These two dimensions **MUST** be the same. Adjust the template until the diagonal measurements are identical.

Once the template is "square", mark the post locations using the **INSIDE** corners of the framed box on the concrete slab with a pencil. After all the post locations are marked on the concrete slab, remove the wooden template. Disassemble it and set the 2x4s aside for use in step 13.

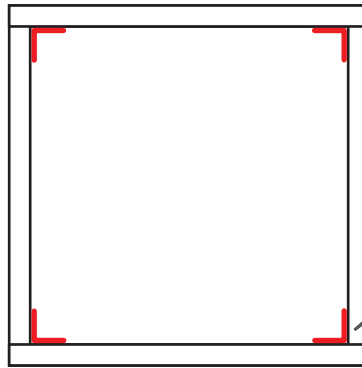

5

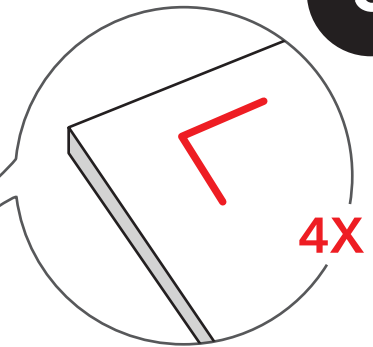

6

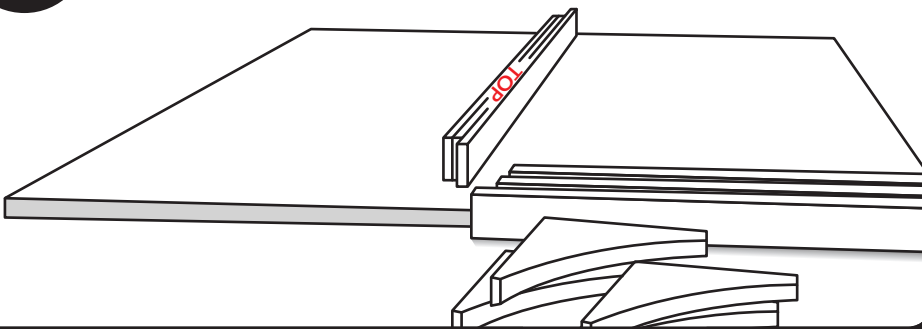

Begin by assembling the frame of the Pavilion structure. Please note that the Pavilion kit includes some pre-assembled pieces.

All of the corner posts will have 2 sides notched. Turn the notches on the post to the outside to accept the headers. The 2 center posts will have 3 sides notched. The unnotched side will face inside the pavilion.

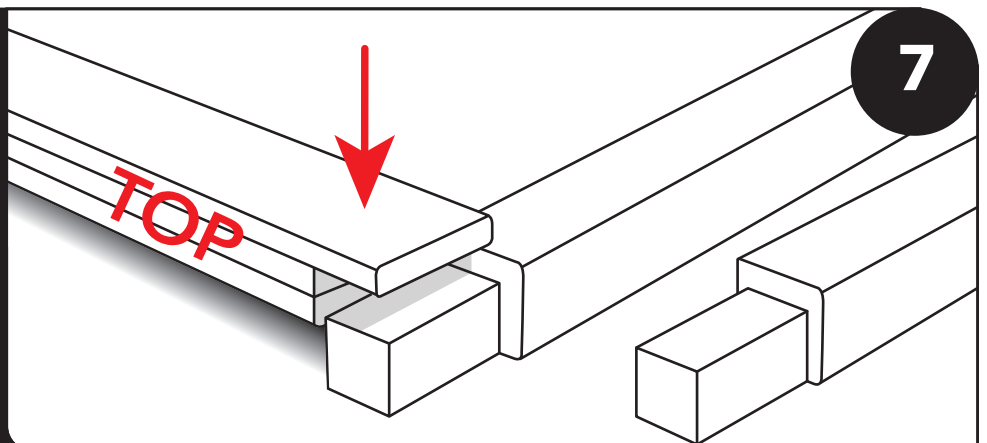

7

4

8

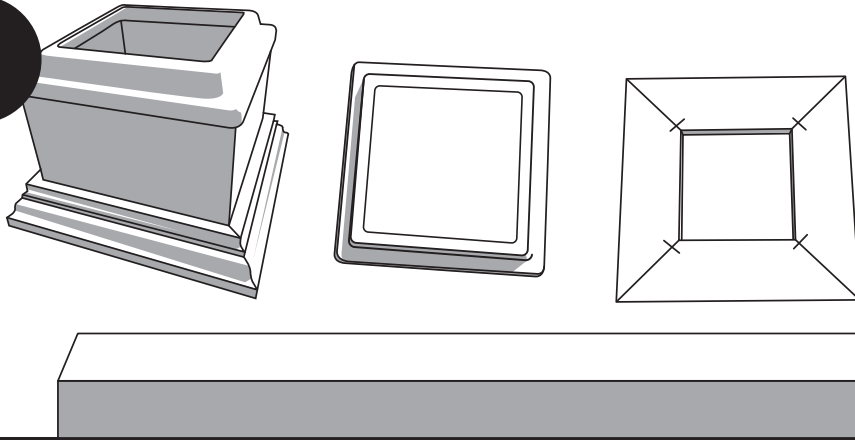

Collect post components to be placed on posts (Bottom post trim, top sleeve trim, top square trim, and post sleeve). **NOTE: If you ordered an electrical package, there will be a 6X6 post with a notch in one side. Put the sleeve with the receptacle on that post as you complete step**

Assemble post vinyl kit. **NOTE: The notched side is the top.** With the post on the ground, slide the sleeve onto the post. Now install the base trim from the bottom. Slide the sleeve trim on from the top followed by the square trim. Complete this on all 4 posts and then set the posts upright.

If you ordered Heavy Duty Anchors for High Wind, see page 27 Step 1 prior to standing up the post.

9



10

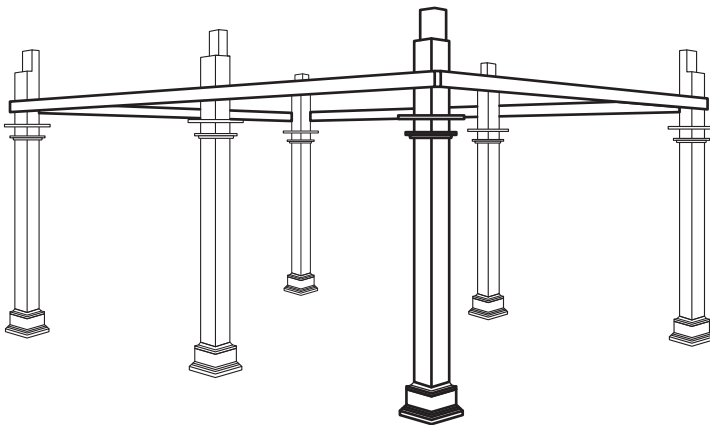

When you have all posts at marks, fasten the template boards to the tops of posts. Make sure all posts components are on, as you cannot put these on later. Make sure all posts are level and everything is square.

Starting with the center post from step 10, attach header with two 3 1/2" screws (not in pre-drilled holes) to hold header in place.

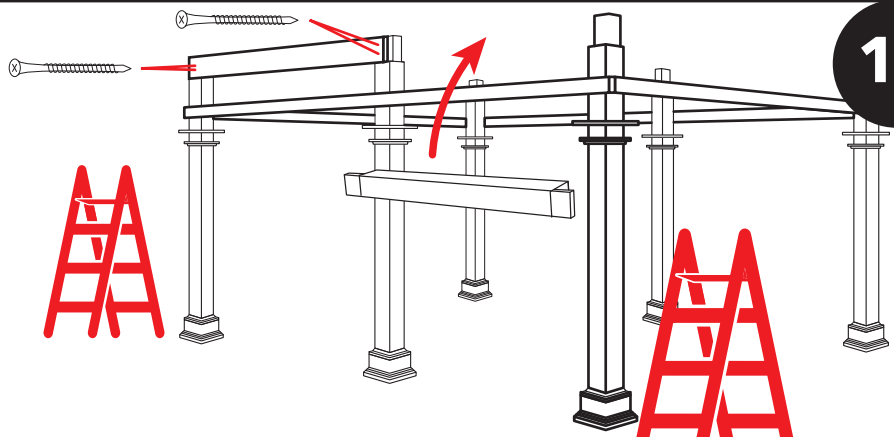

11

12

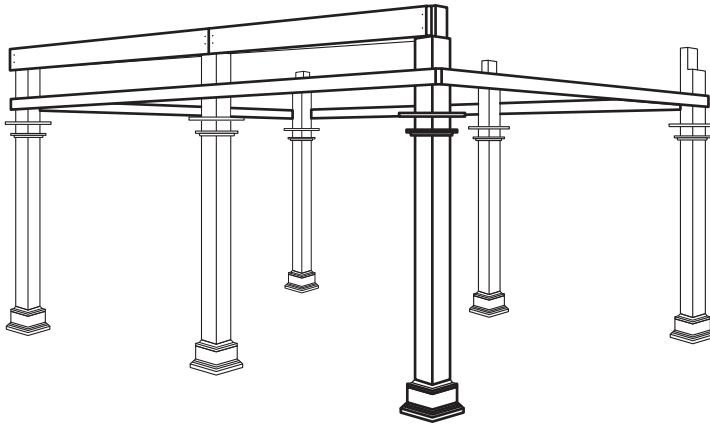

Attach short end headers with three 3 1/2" screws (in the pre-drilled holes) into the end of the other two beams. Repeat on opposite side with the last remaining beam.

Locate twenty-four 8" GRK screws in the hardware box (if you have a standard 4 post structure). Those go in the pre-drilled holes at the corners of the beams.(6 per corner)

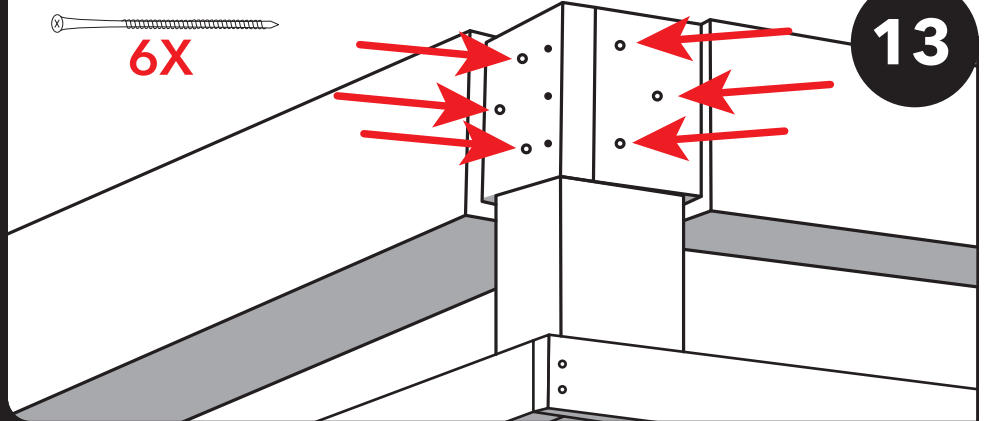

14

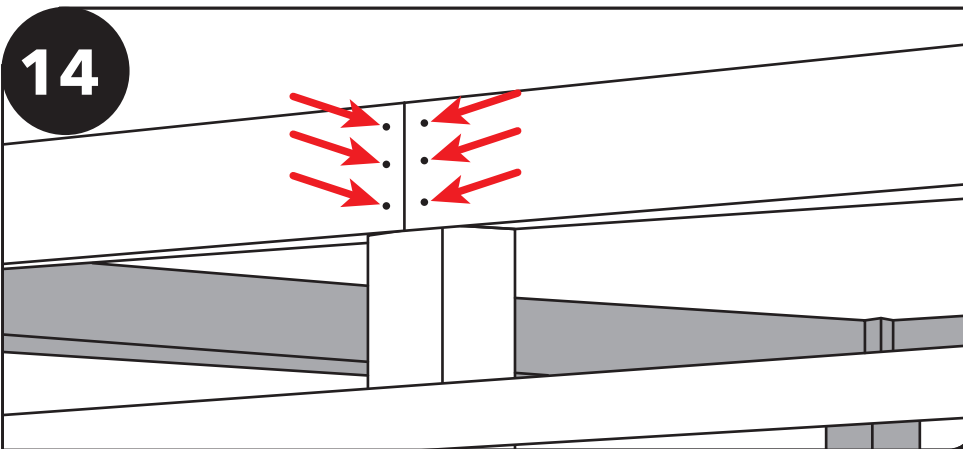

Locate the 12 GRK 4" screws. Screw three GRK 4" into left and right side of the header seam on the center post (using the pre-drilled holes). Repeat on the opposite side of the pavilion anchoring your last two beams.

Make sure the posts are all level and everything is square. With base trim still raised, fasten two L-brackets on the outside edges of each post with five 2 1/2" screws per bracket. Some engineering specifications may require 4 brackets per post. **NOTE: For HD High Wind brackets see bracket appendices on page 27 Steps 2-4.**

6

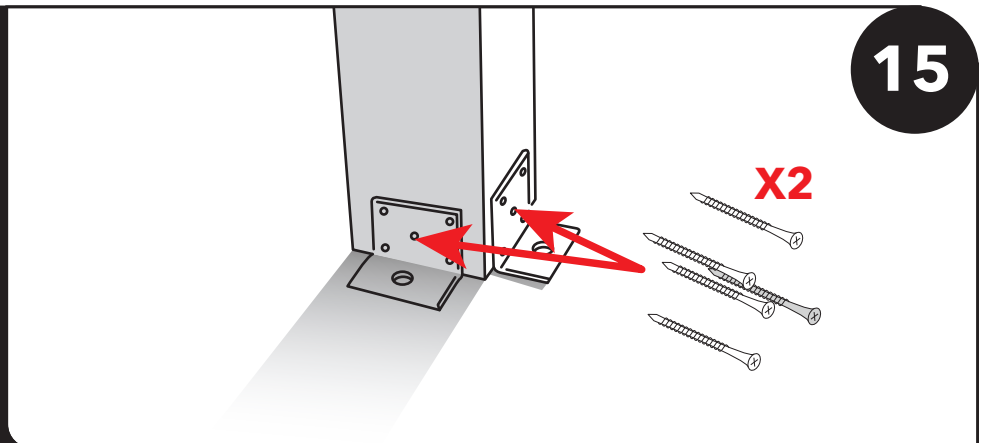

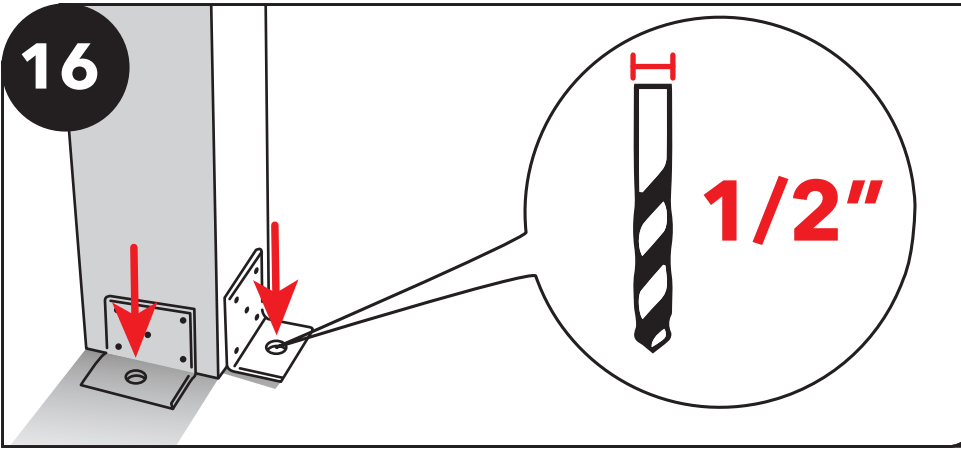
16

When all posts have two L brackets on, use a drill with 1/2" masonry bit to drill down about 1/2" farther than length of wedge anchor.

Before inserting the bolt, make sure dust is removed from hole. Then screw the nut and washer on about 1/8" below the top of the bolt. Next, insert the wedge anchor bolt into the hole. To protect the threads and nut, tap the bolt into the ground with a piece of wood as a buffer.

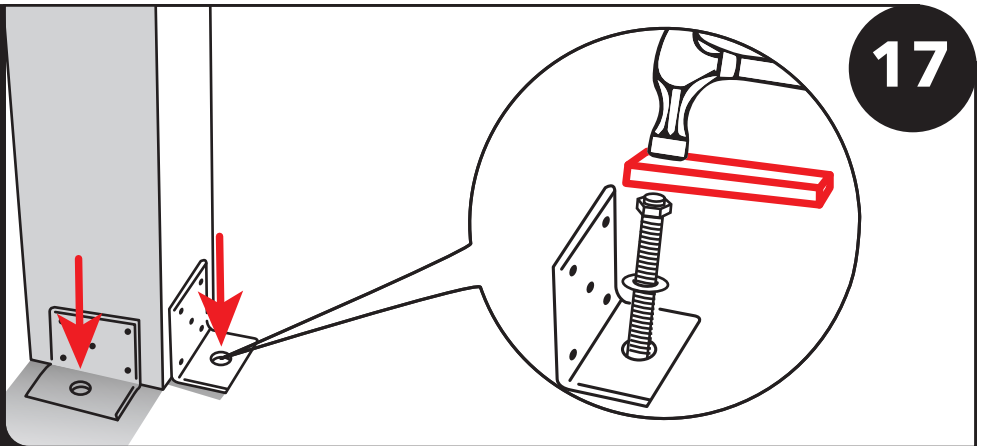
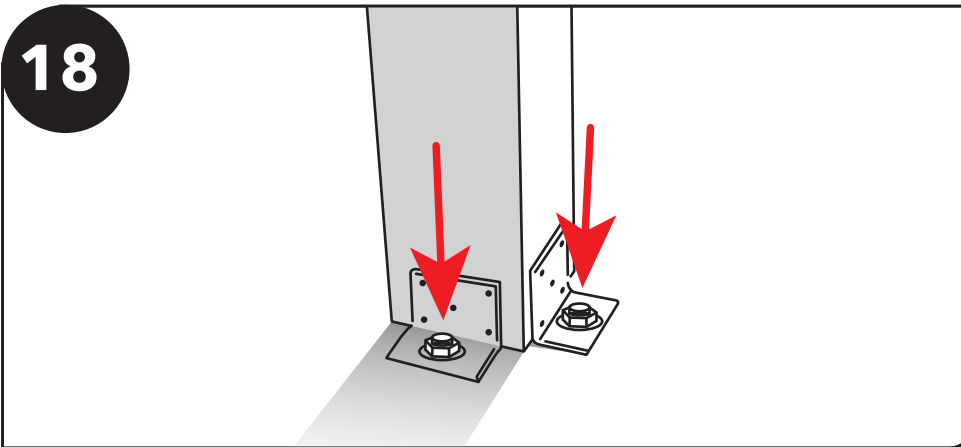
**18**

Once the wedge anchor is pushed down against the bracket, use a wrench and tighten it down. Do that with all the anchors.

When all of the nuts have been tightened fully and the posts are securely mounted to the concrete slab, slide the sleeve and post trim down.

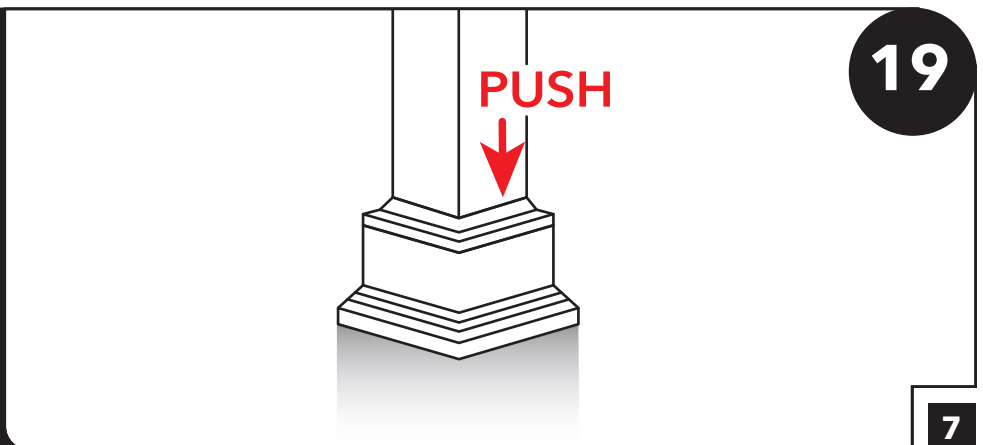

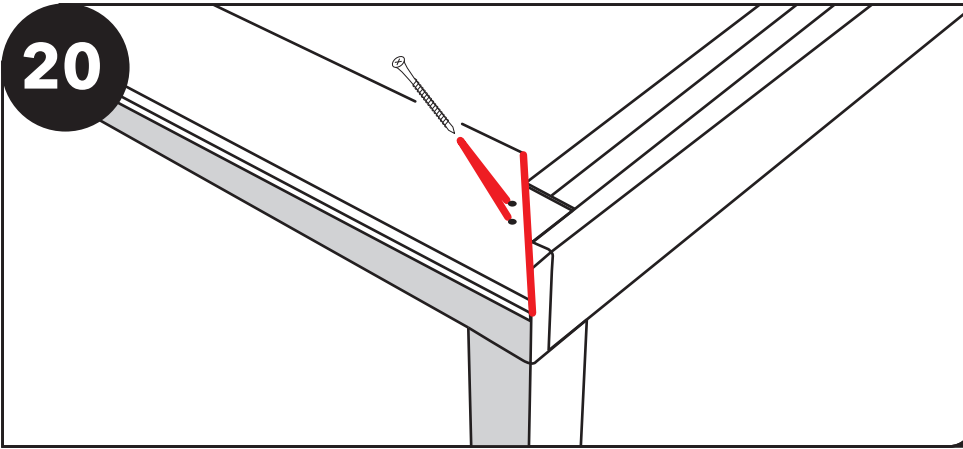
20

Install the four 2X12 top plates. The top plates should mount close to flush with the inside post. Make sure that the overhang is the same on both sides. Use two 3 1/2" screws to fasten the plates to the posts. Do not cut these without calling. Be sure that the vinyl side faces downward.

Squarely align the two 2x12 plates forming a right angle. It is important that the top plate boards equally overhang the structure to accurately center the roof. Fasten the two 2x12 plates together at the corner with one 3 1/2" screw. Once you have all four corners together, put two 2 1/2" screws down into the header approximately every 16" all around.

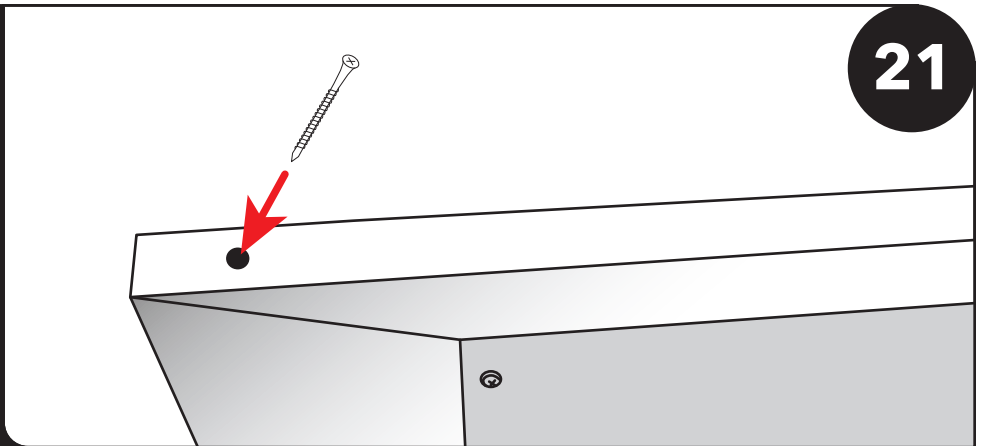
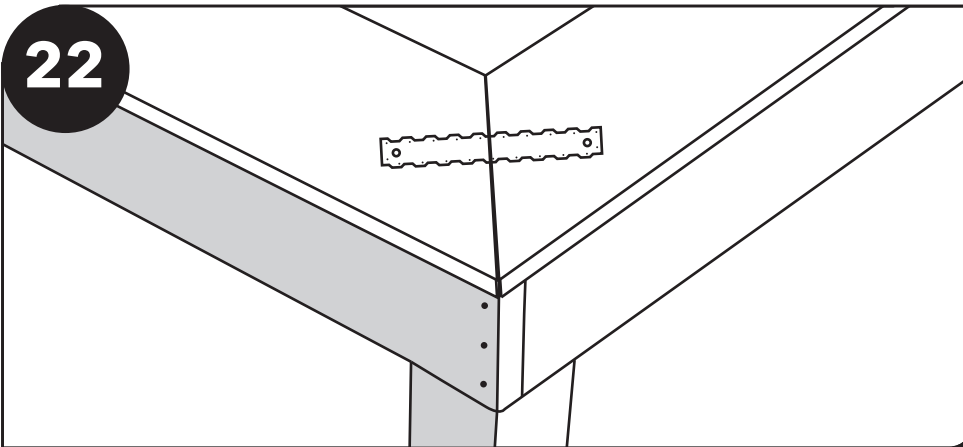
**21****22**

Fasten tie straps, ST2215, with 1 1/2" screws at every seam on the top of the plate.

Fasten the marked "Side Rafters" to a marked "Ridge Pole" at each "X", keeping one edge of the rafters flush with the vertical line and the top edge flush with the top of the ridge pole. If you ordered a square pavilion, turn to page 28 and follow the instructions.

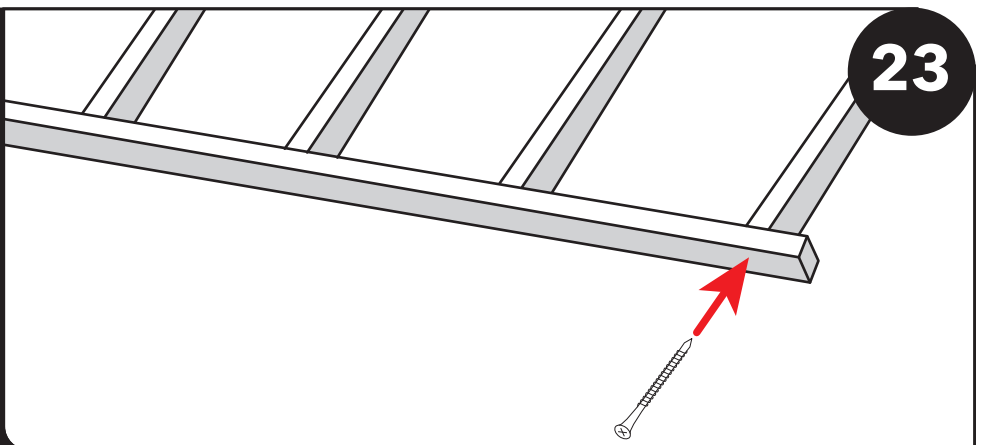
**23**

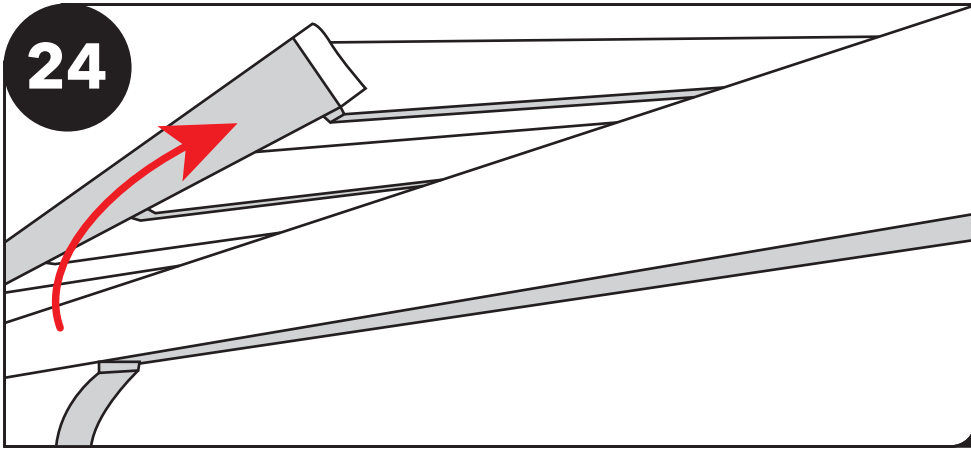

Set finished sections up onto plate.

Screw the two sections together at the top with two 2 1/2" screws between every rafter. Keep ends even.

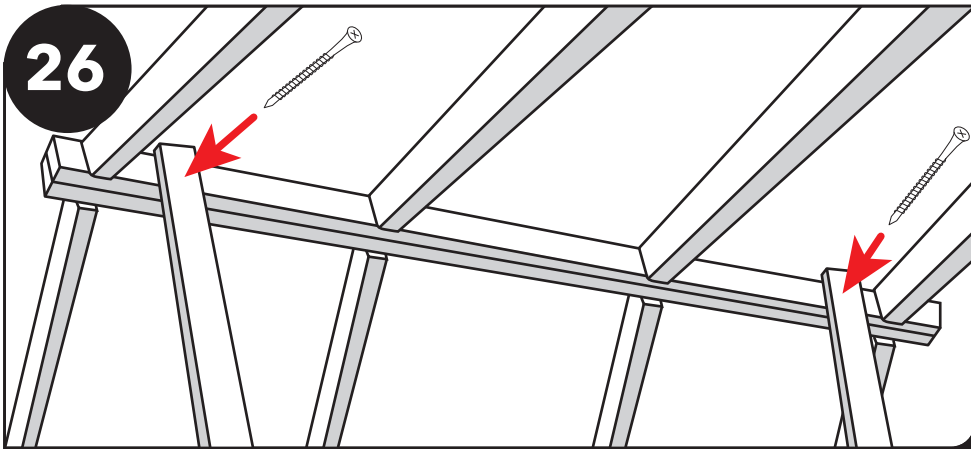
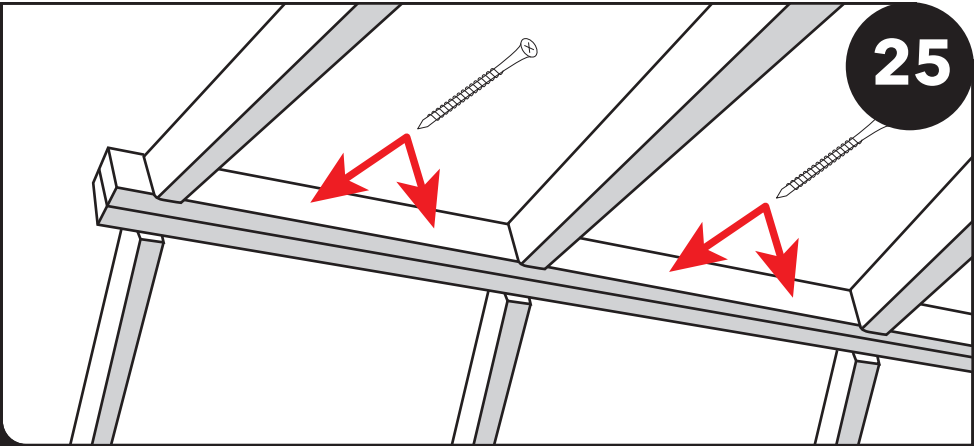

Fasten two 2x4 temporary props at either end of ridge pole to hold in place.

Anchor each rafter to the plate on the marked "X"s using three 3 1/2" screws, staying flush with the vertical line keeping 1/4-1/2" away from the edge of the plate.

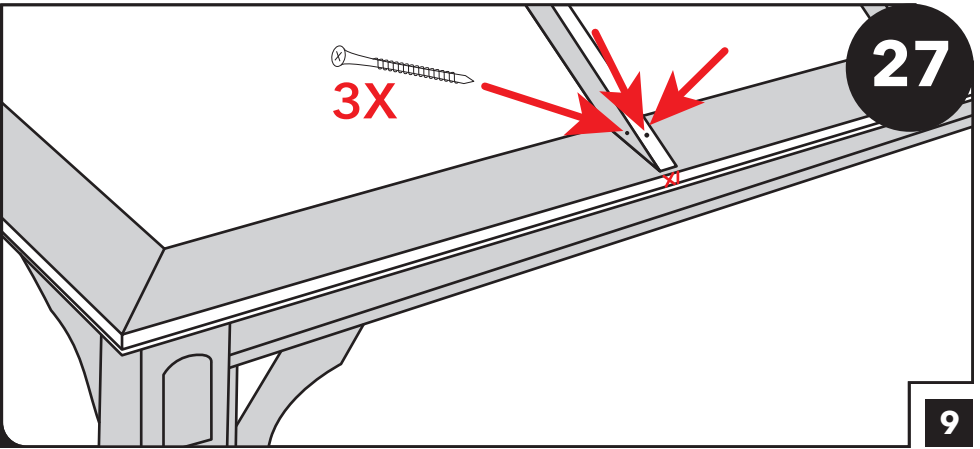

28

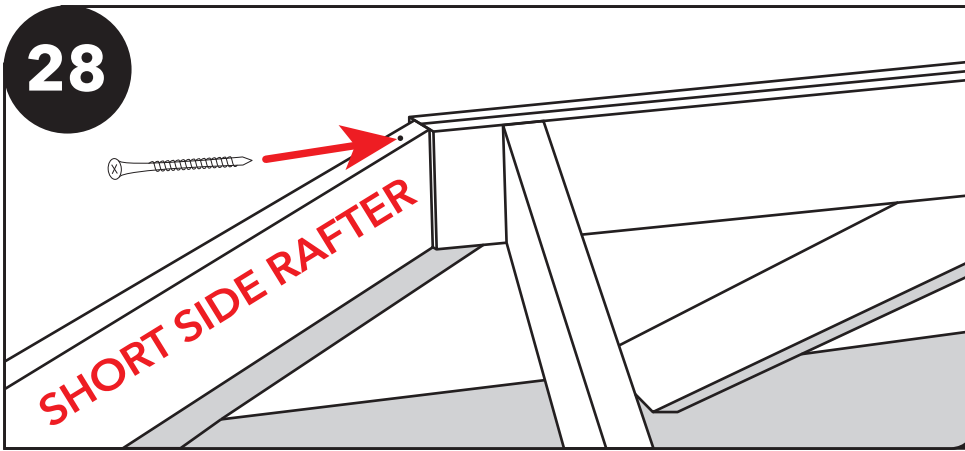

Fasten the marked "short side" rafter to the ridge pole using one 2 1/2" screw, keeping flush with top of ridge pole.

Assemble top of hip rafter to ridge pole using two 2 1/2" screws.

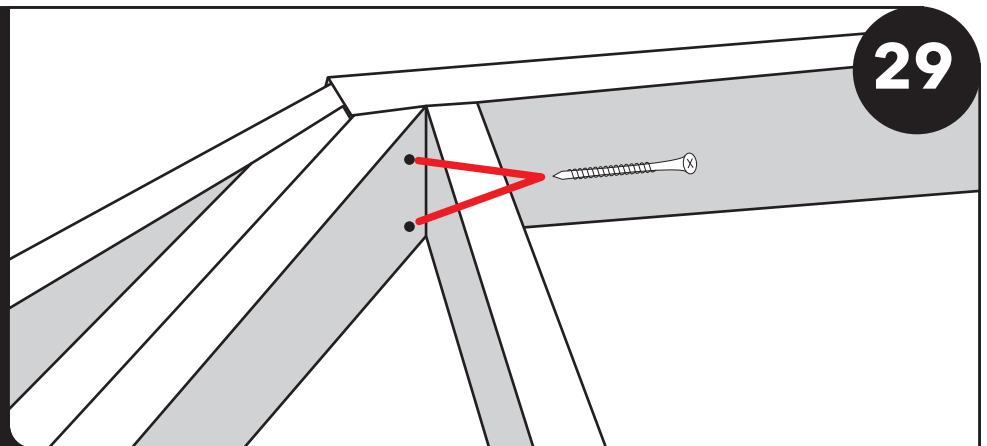

29

30

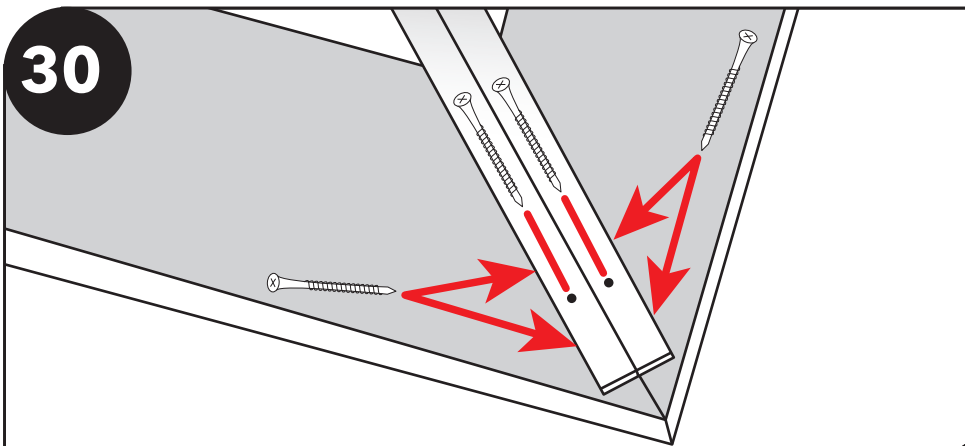

Secure the bottom of each hip rafter with six 3 1/2" screws into the corner of the plate.

Identify your jack rafters. The jack rafters are shorter than the side rafters and have a bevel cut on the upper end.

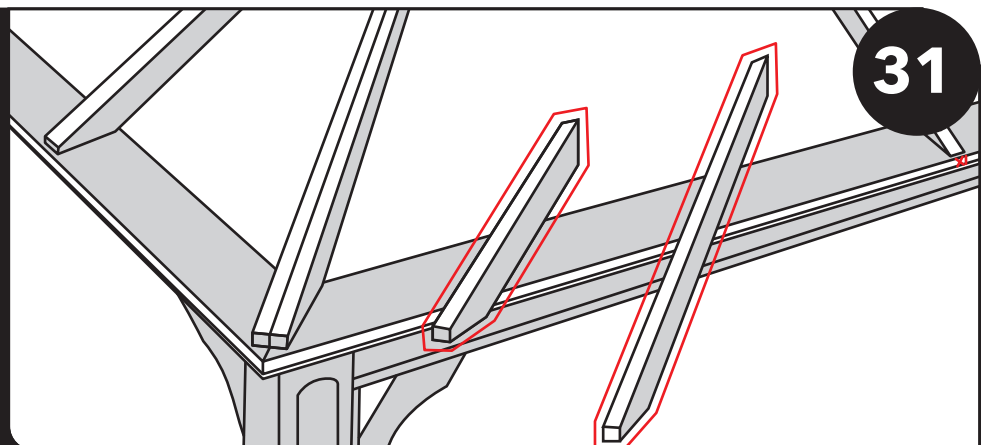

31

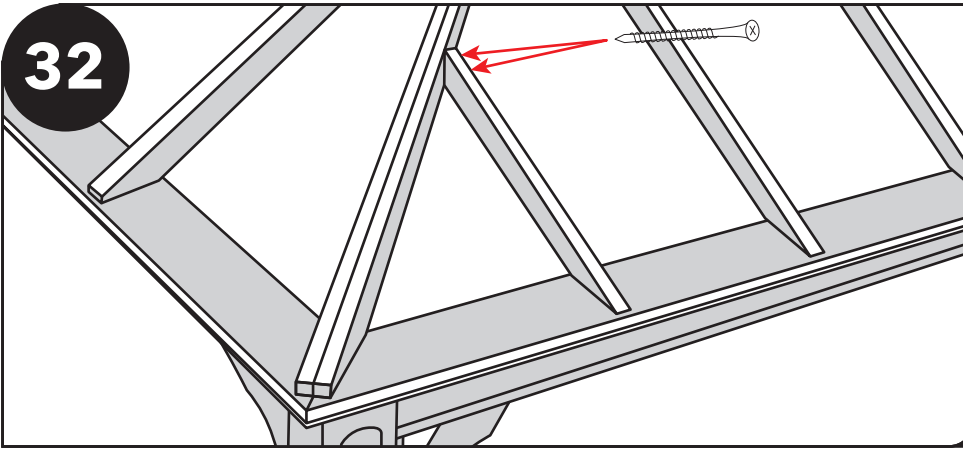
32

Jack rafters will only fit properly on left or right side based on upper bevel angle. Fasten correct jack rafter into the hip rafter with two 2 1/2" screws staying 1/4-1/2" in on the edge of the plate.

Measure from the top of the jack rafter to the side of the side rafter. Repeat the measurement on the lower end of the jack rafters before fastening to ensure equal distance at top and bottom.

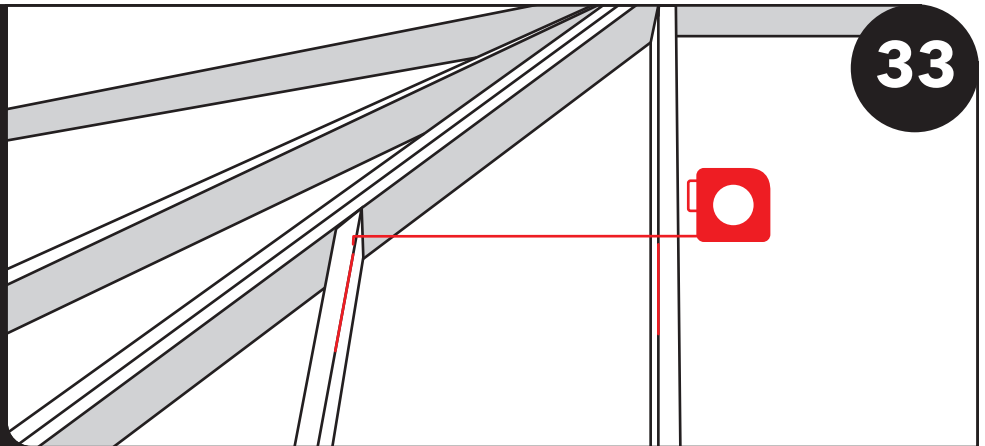
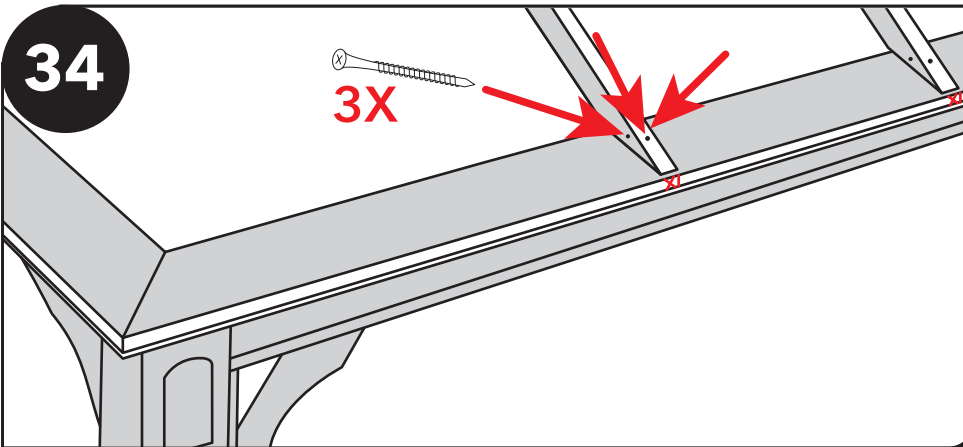
**33****34**

Anchor each rafter to the plate on the marked "X"s using three 3 1/2" screws, staying flush with the vertical line keeping 1/4-1/2" away from the edge of the plate.

Fasten two 'A23 Simpson' brackets with 1 1/2" screws on either side of each corner hip rafter and one 'A23 Simpson' bracket at each side rafter and jack rafter.

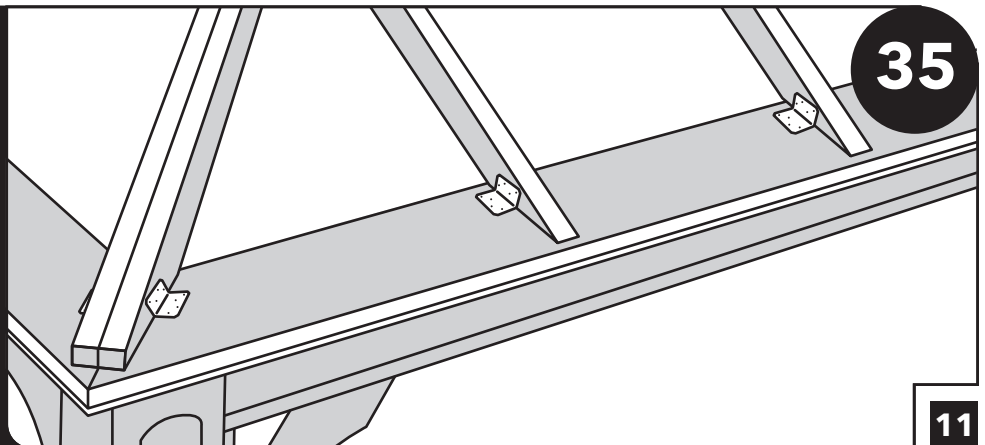
**35**

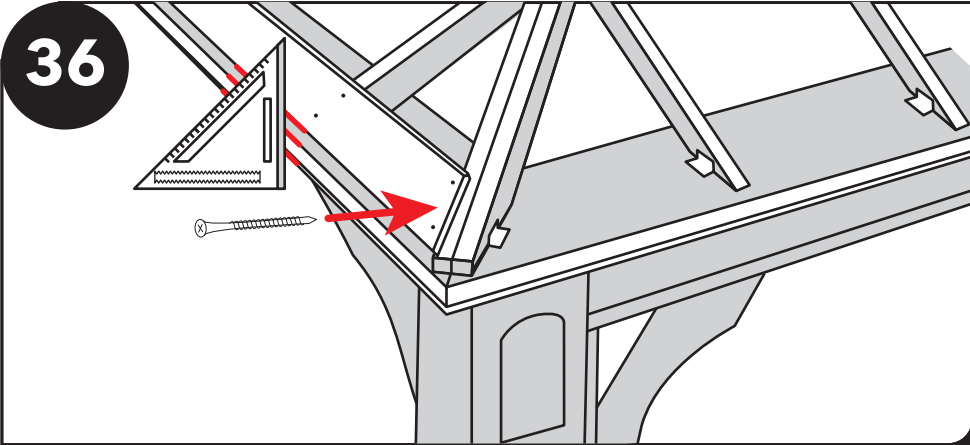

Install the first piece of roof decking making sure not to extend past plate edge. Board may need to be cut to length. (At times decking may need to be spliced on a single rafter.) Fasten decking using two 2" nails per rafter.

Securely interlock each piece of the roof decking, starting from the bottom and working up.

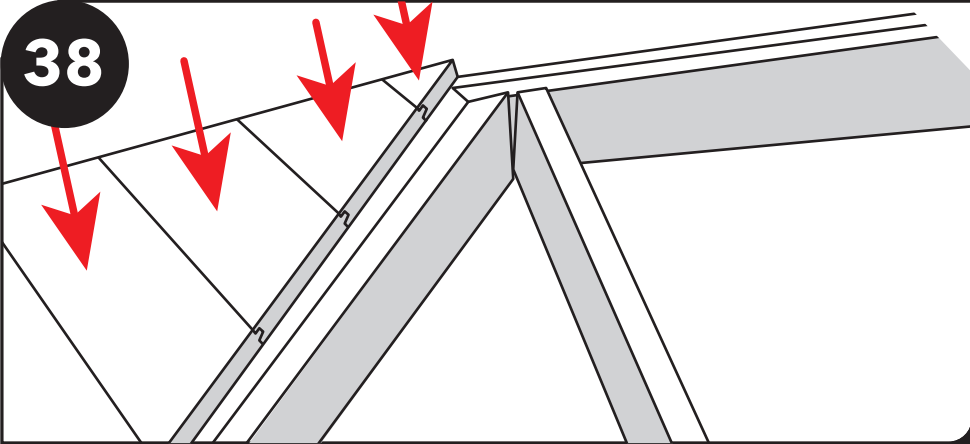
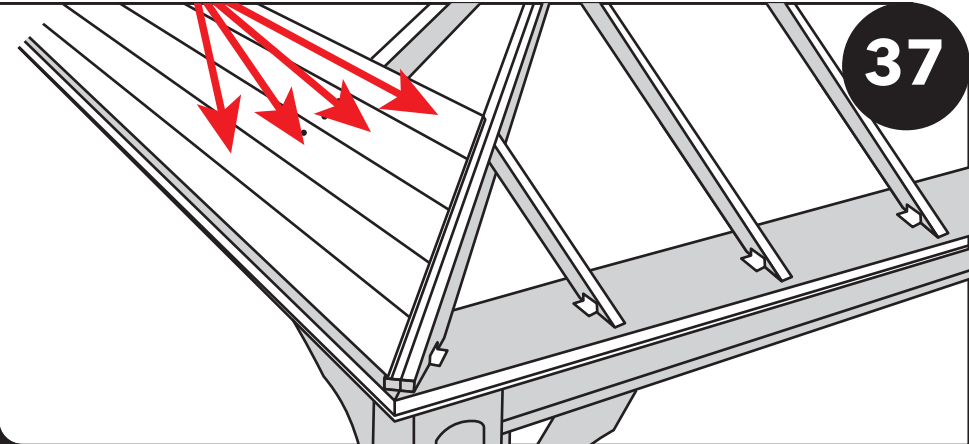

Repeat on all four sides.

Starting on the long side, hold fascia in place butting the top of the fascia board against a square, following the pitch of the decking. Fascia should not be lower than the pitch of the decking; the end of the fascia should remain flush with the end of the plate.

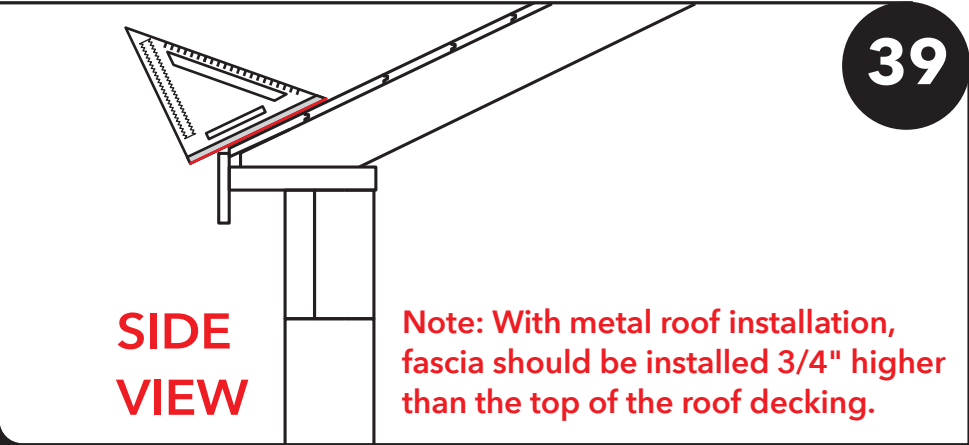

SIDE VIEW

Note: With metal roof installation, fascia should be installed 3/4" higher than the top of the roof decking.

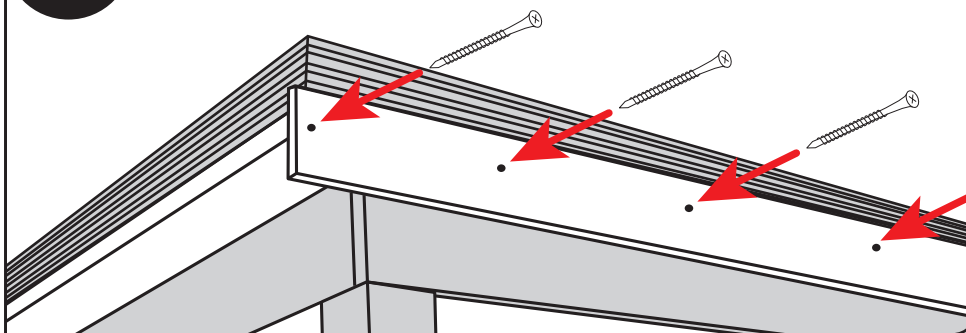
40

Next, drive 2 1/2" screws every 16" along the entire length of the fascia board. Follow these same steps with the other short-sided fascia board.

Moving to the short side, hold fascia in place, butting the top of the fascia board against a square following the pitch of the decking. Fascia should not be lower than the pitch of the roof decking; the end of the fascia should extend out to be flush with the long side fascia board.

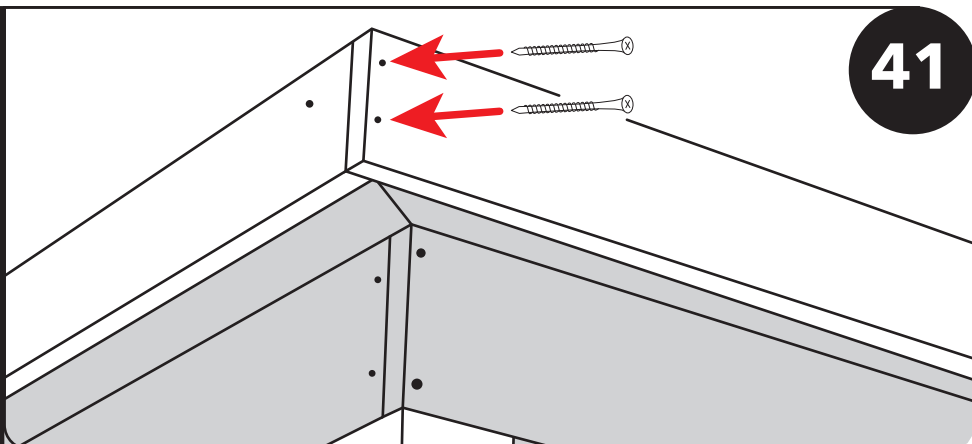
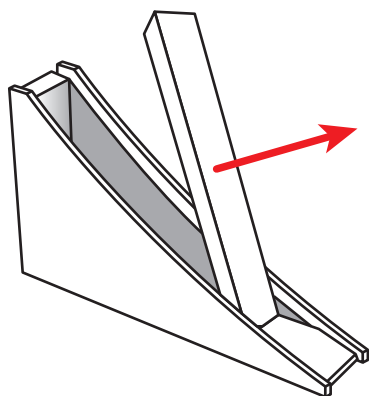
**41****42**

Locate the corner braces. Take the 2x4 board out from center of brace.

Keep the brace flush on the outside of the post. Fasten to post with two 3 1/2" screws and up into the header with two 3 1/2" screws. Line the top of the brace up with the header seam above staying 5/8" from flush. Being sure to keep the back of the brace flush with the post below.

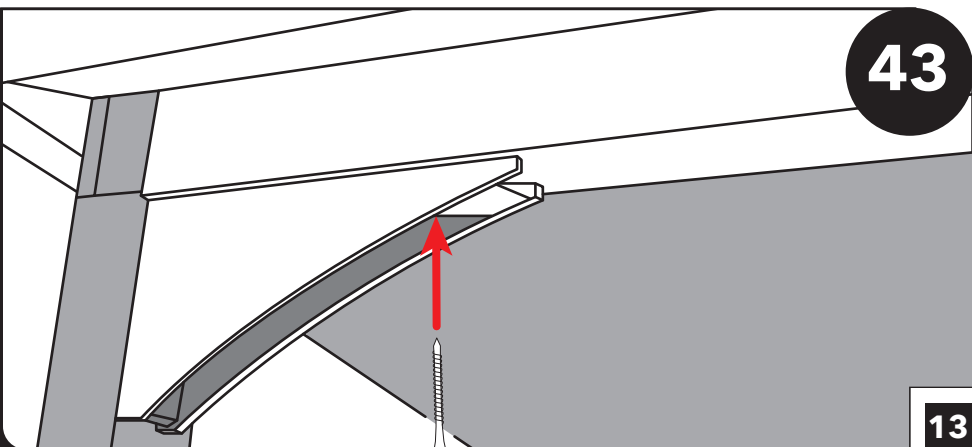
**43**

44

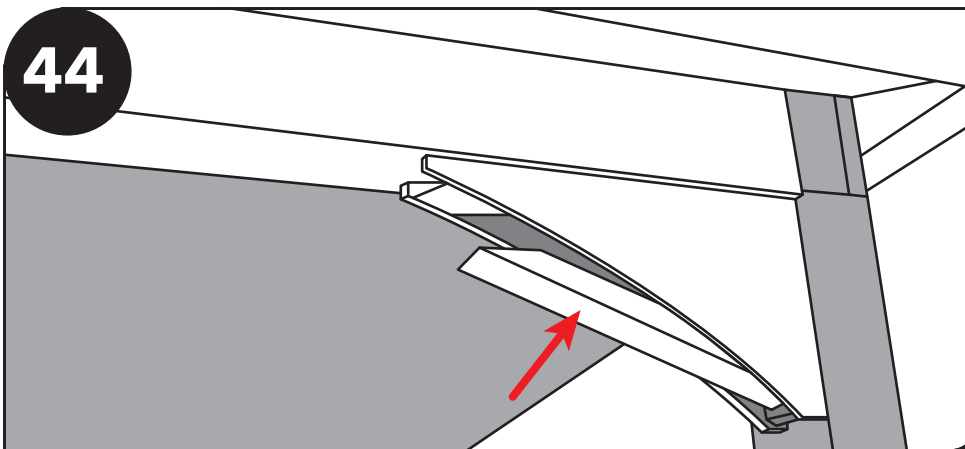

Once you have all the braces installed, put the 2x4 block back in place, fasten with two 2 1/2" screws at the top and two 2 1/2" screws at the bottom.

Install the bottom brace covers using three 2 3/4" Cortex screws. Continue with all 8 braces.

Use Cortex counter-sink bit

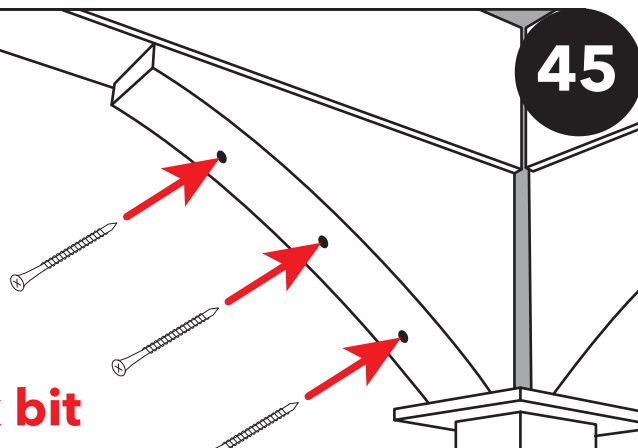

45

46

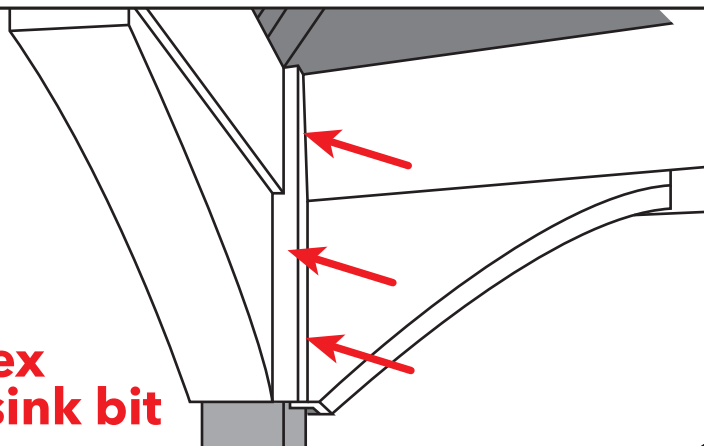

Use Cortex counter-sink bit

Install the inside corner trim. Fasten with three 2 3/4" Cortex screws.

Place the outside corner trim box flush against the header and the brace, being sure that the top corner point is centered on the plate seam. Fasten with six 2 3/4" Cortex screws into the pre-drilled holes on the face of the corner trim.

Use Cortex counter-sink bit

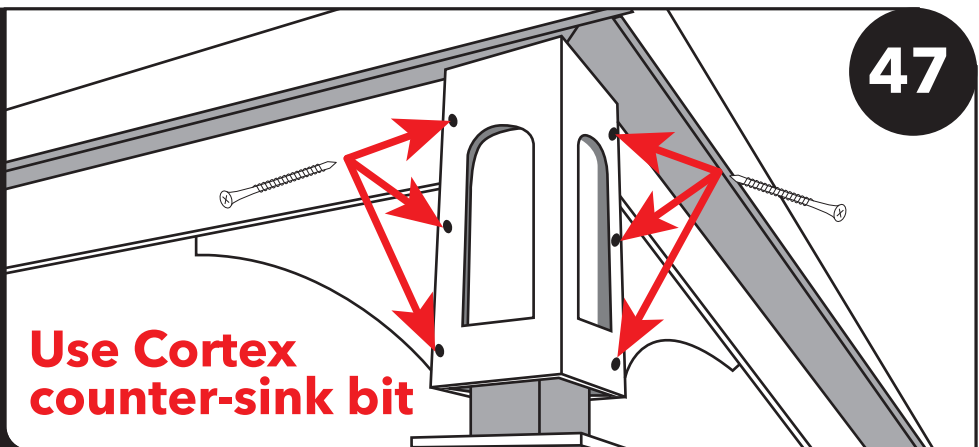

47

48

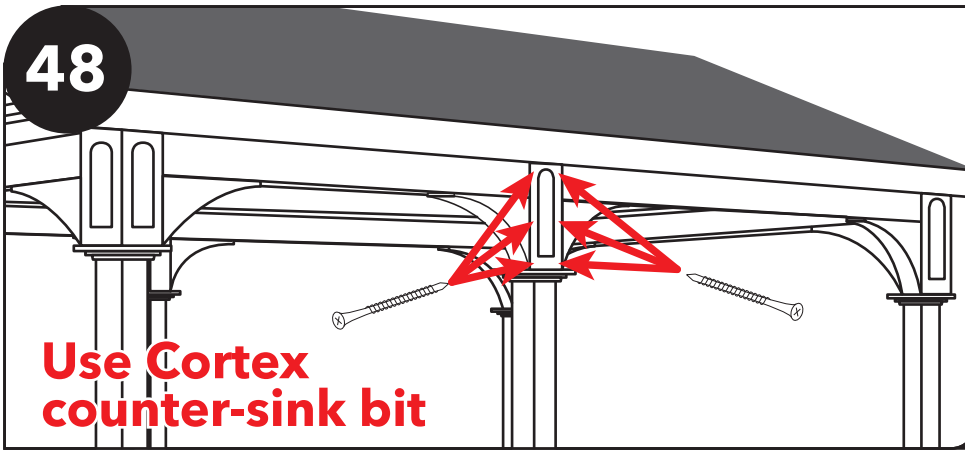

Use Cortex counter-sink bit

Install the outside center trim by fastening it to the top of the center post with six 2 3/4" Cortex screws into the pre-drilled holes on the face of the outside center trim.

Install the inside center trim by fastening it to the top of the center post with six 2 3/4" Cortex screws into the pre-drilled holes on the face of the inside center trim.

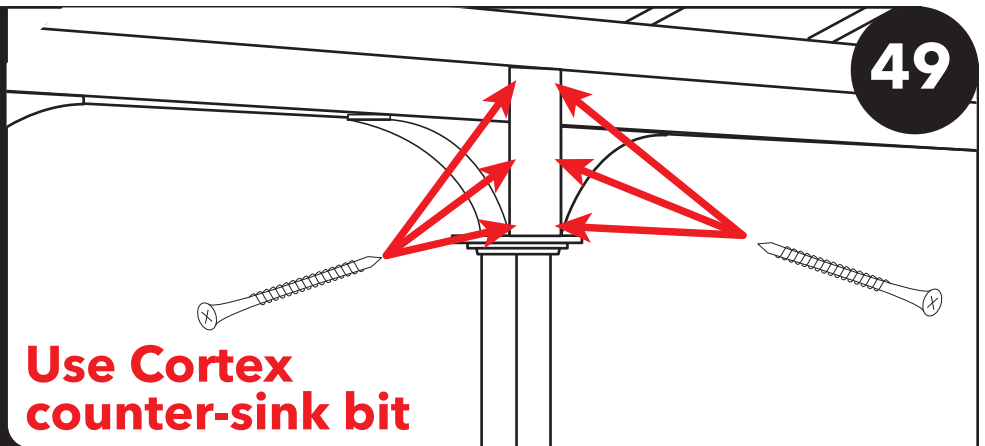

49

Use Cortex counter-sink bit

50

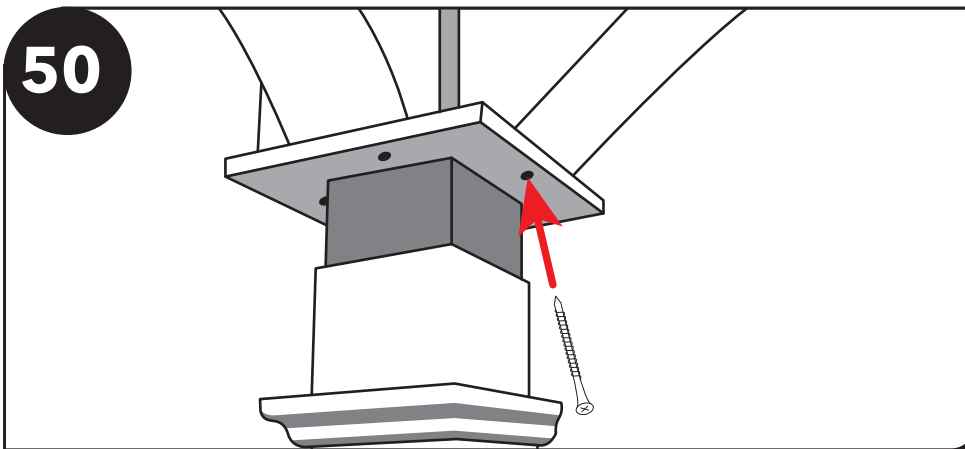

Fasten top square trim to bottom of braces with four 2 1/2" screws. Repeat on all posts.

Slide the 6x6 top sleeve trim up to the top square trim and fasten with 1 1/2" pan head screws one centered on every side. Repeat with all posts.

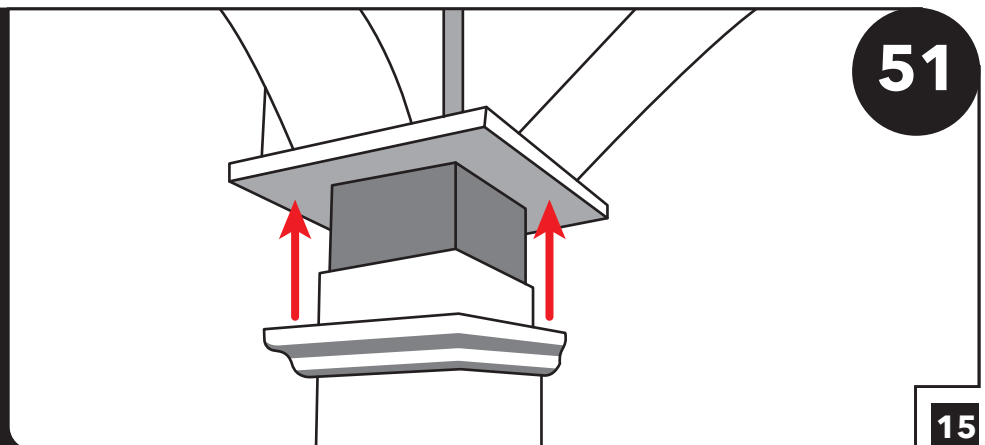

51

52



Plug all countersunk Cortex screw holes with provided plugs, and using the provided caulk, caulk all gaps in the trim components. Congratulations! You are now ready to install your roofing option.

Installing Collar Ties

Your pavilion kit may include collar ties. Collar ties prevent the middle of the main beams from bowing outwards due to the downward pressure of the roof due to gravity (i.e., the weight of the roof).

1

Identify the collar ties in your kit. A collar tie is a 2x4 (2x6 for larger sized pavilions) with the ends mitred to match the pitch of your roof, like this:



For the purposes of these instructions, we will assume you have a 2x4 collar tie, rather than a 2x6.

2

If you have only one collar tie, you will fasten it to the center rafter (skip to Step 4 on the next page). If you have more than one collar tie, space the collar ties on the ground evenly along the length of the structure, each collar tie directly below a rafter.

3

Grab a collar tie and raise it up to the interior ceiling of the structure. Push the collar tie up against the bottom of T&G so that the mitred end of the collar tie is flush with the bottom of the T&G, and the 4" face of the 2x4 is flush against side of your rafter.

4

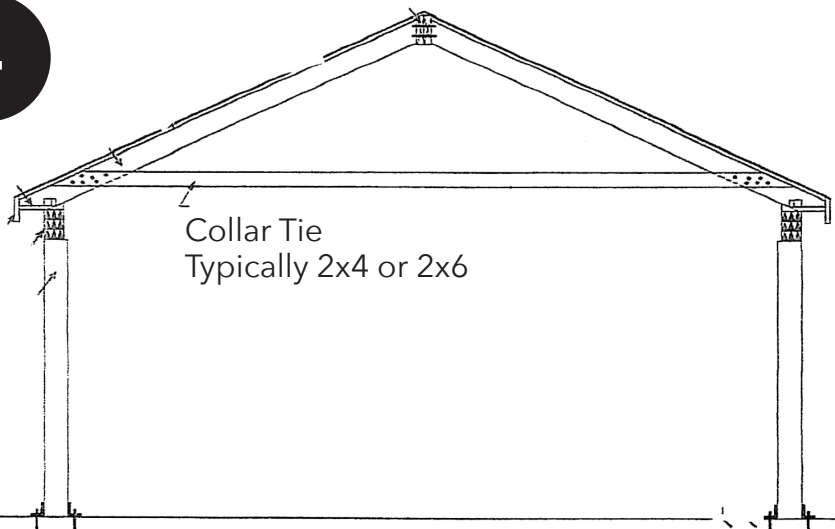

Fasten the collar tie to the rafter with six 2 1/2" screws at each end of the collar tie.

Roofing Option 1: Installing A Metal Roof

Fasten horizontal "Roof Lath" pieces with two 2" roofing nails at each rafter. Place the first piece of lath directly on top of the lowest decking board. Space each lath board roughly 20-24" apart with the longest piece placed at the bottom and the shortest piece at the top. (Lath boards may need to be cut to length.)

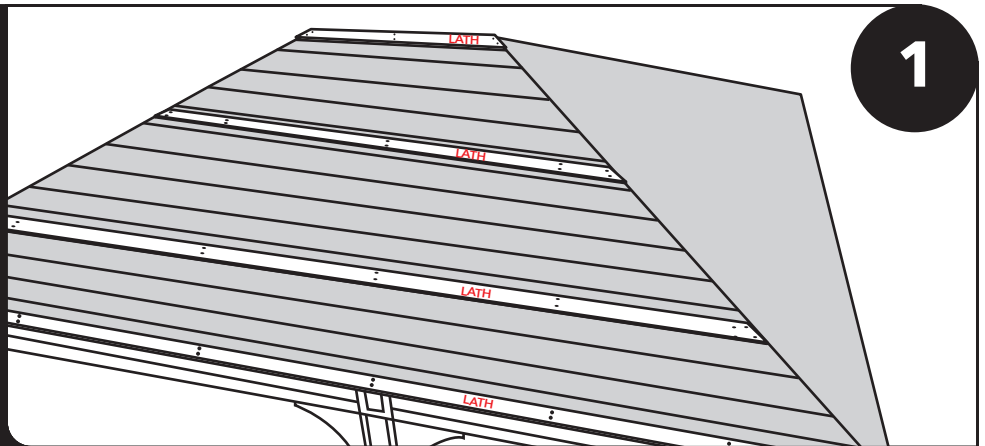

2

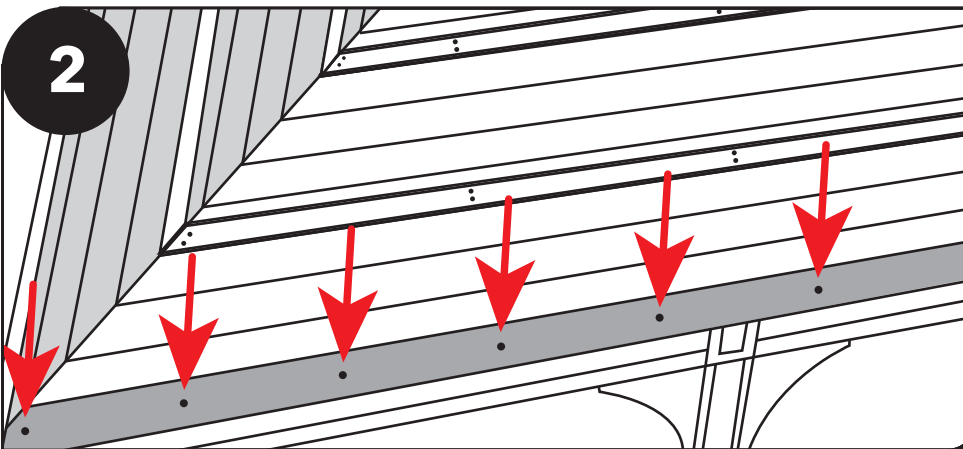

Install the drip edge over the bottom lath piece. Cut each piece to length. Fasten with 1" screws, staples, or nails every 16".

Install the ribbing roughly 1 1/2-2" from the bottom of the drip edge. Do not stretch the ribbing because the grooves of the roof must line up with the ribs.

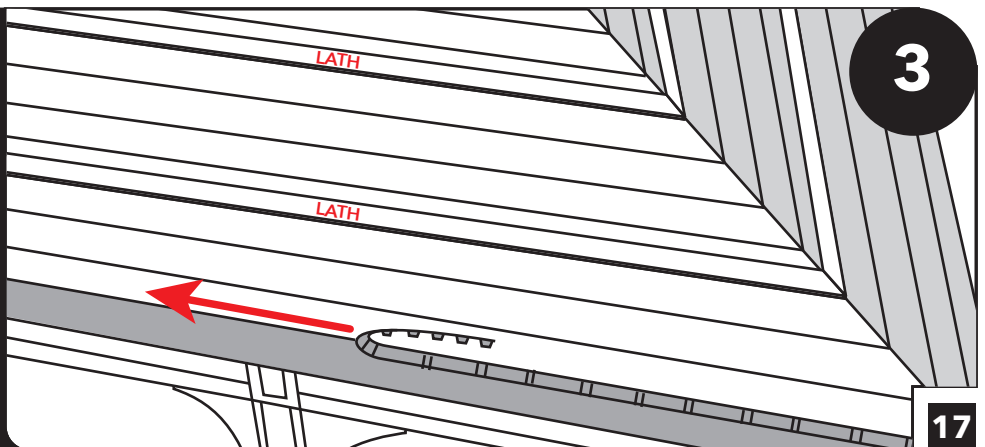

4

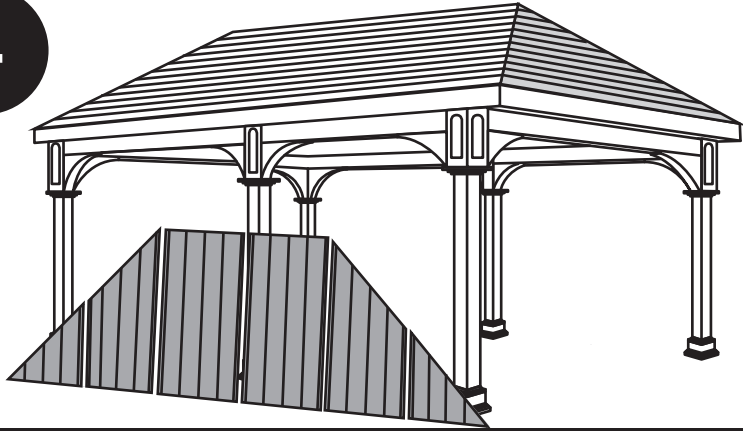

Lay out the roof tin.

Install the tin, starting at the center and moving to each end. Ensure the first piece is installed squarely. Keep the bottom of the tin flush with the drip edge. Fasten with 1" screws. The first piece will have 3 screws at every lath.

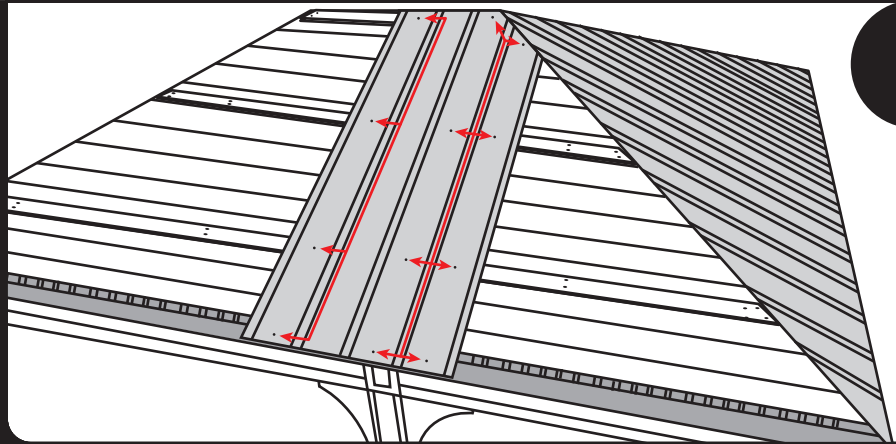

5

6

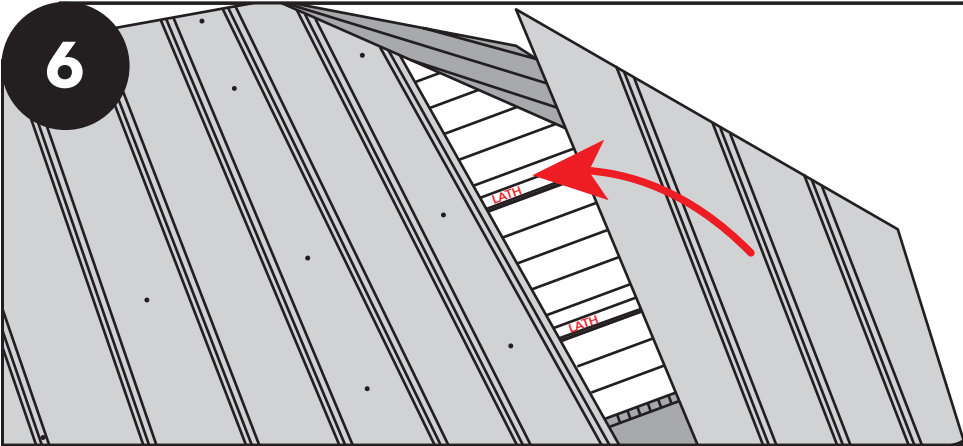

Repeat step 4 on all sides.

Peel backing off of the foam and apply foam to the tin roof. Make sure not to go wider than the hip capping.

TOP
DOWN
VIEW

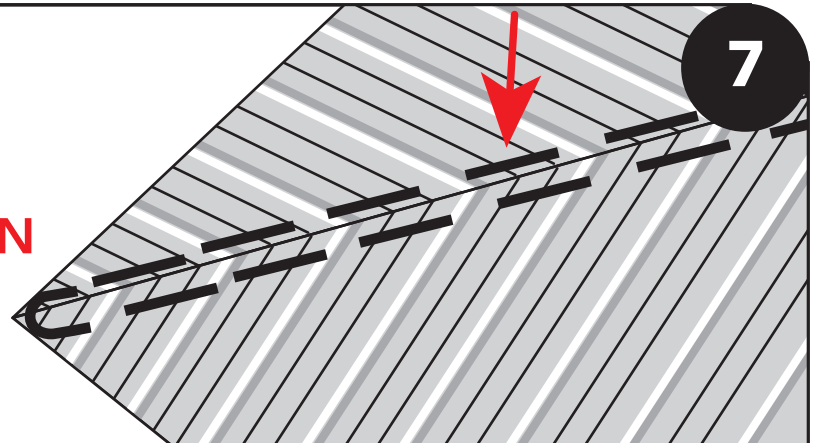

7

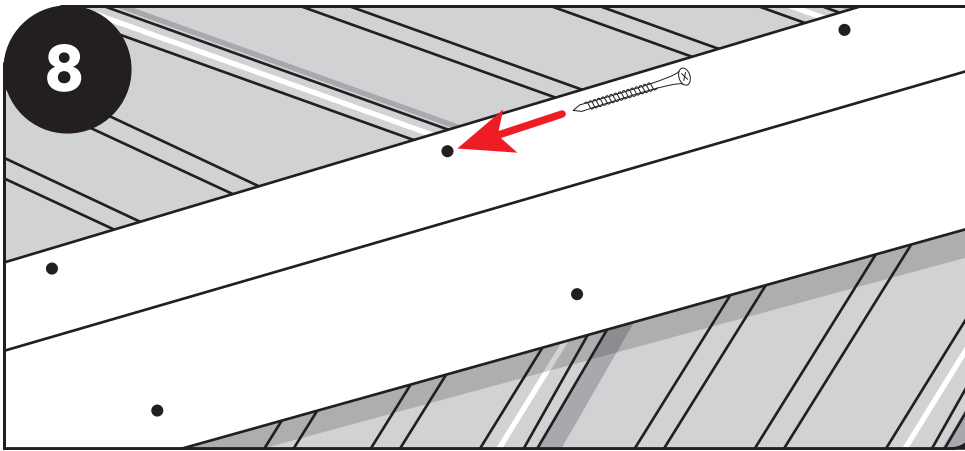

Fasten hip capping with 1 1/2" screws on the tall ridges.



Fasten ridge cap with 1 1/2" screw every 24" on both sides.



Roofing Option 2: Installing An Asphalt Roof

NOTE: Before you begin the steps below, install roof paper starting at the bottom. Be sure to overlap 2" as you work upward. Drip edge will then be installed on all edges of the roof, using a fastener every 16".

Roofing Fasteners

Please note we do not include fasteners for asphalt shingles with our kits. This is because some states require different fasteners than others, and because some customers have different tools than others (hammer, nail gun, pneumatic stapler, hammer tacker, etc.).

Please use shallow depth fasteners to fasten your shingles to your 1x6 roof decking. For example:

- 5/8" long roofing nails
- Roofing staples with 5/8" leg and 1" wide crown

These fasteners will certainly be sufficient to hold the shingles to your roof in high storm winds, and will not pierce the bottom surface of the 1x6 roof decking.

DO NOT PLACE PLYWOOD, OSB (ORIENTED STRAND BOARD) OR OTHER DECKING ON TOP OF THE 1X6 TONGUE AND GROOVE.

It is not necessary and is too heavy for your structure.

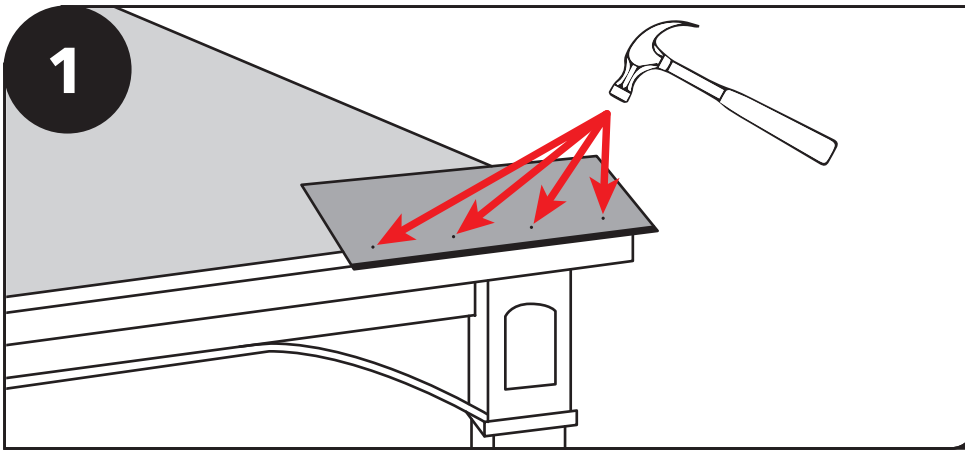

To install 1st row of shingles, turn shingle upside down with black tar line at bottom edge facing up and attach to roof using four 5/8" roofing nails. Place nails approximately 3" from bottom.

Use four 5/8" roofing nails and attach to roof through shingle at the center line marked on the shingle. Do not fasten below the line or your fasteners will be exposed.

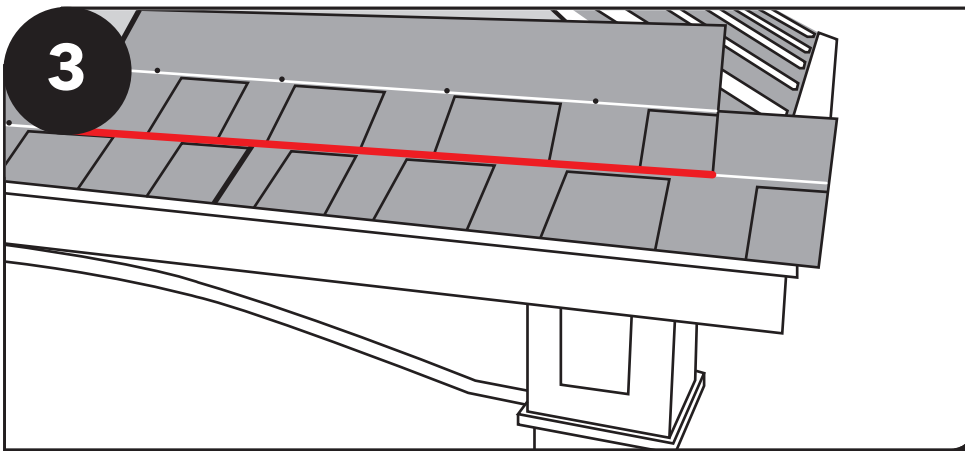
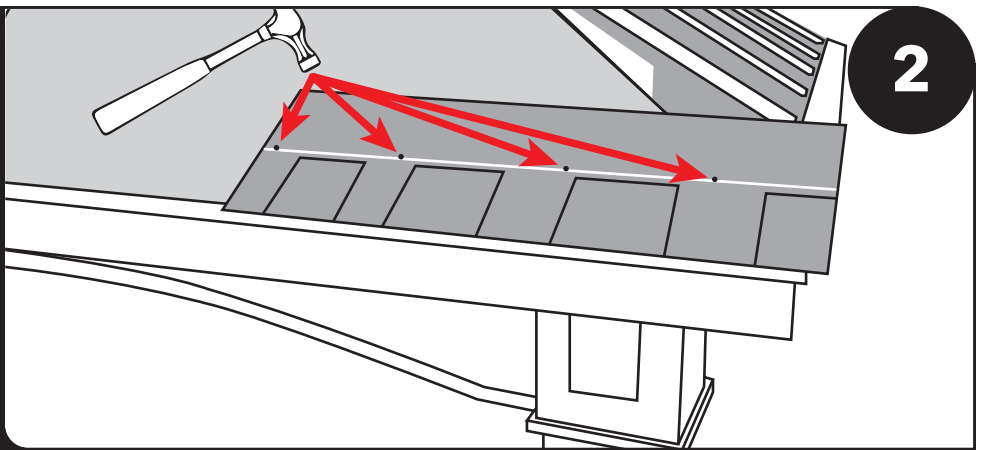

Start second row, line up bottom of shingle with the architectural line on the shingle below.

Attach second row of shingles to the roof using 5/8" roof nails provided or a power stapler. Do not use long nails or staples that protrude through 1X6 roof decking.

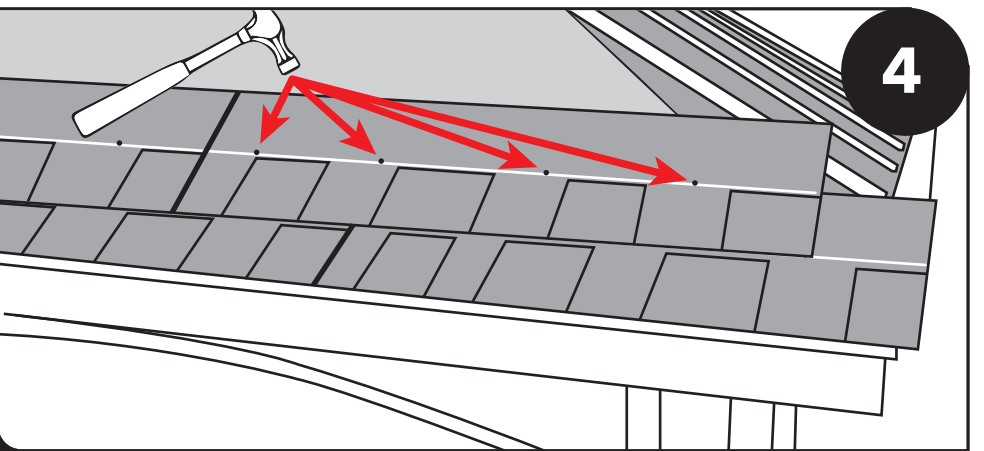

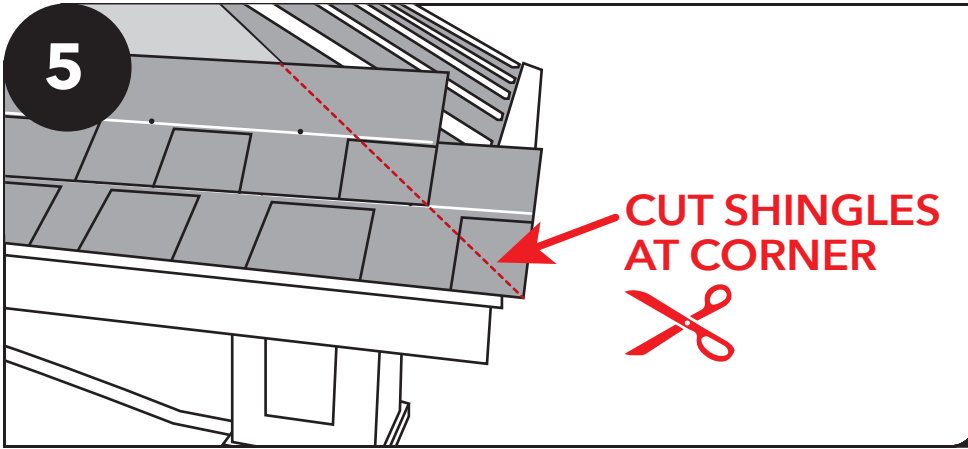

Trim corner shingles using a shingle scissor or utility knife. When using a knife cut on the bottom side.

Also see instructions on shingle package.

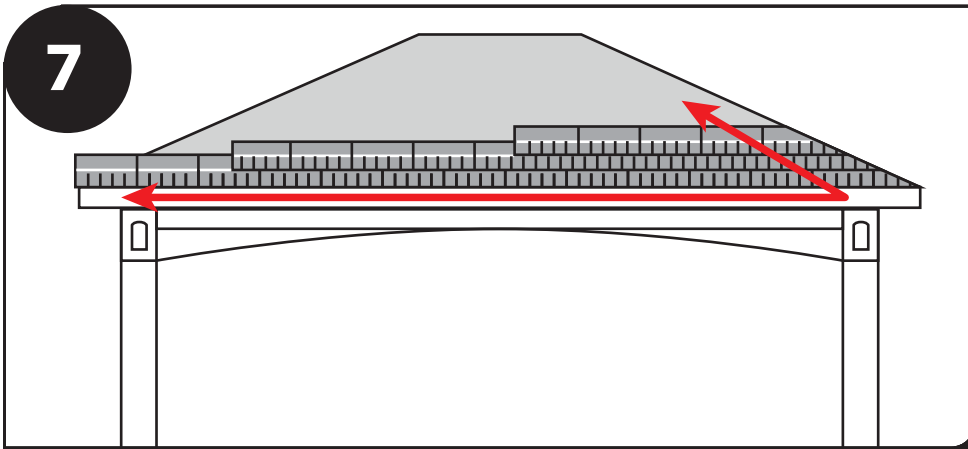
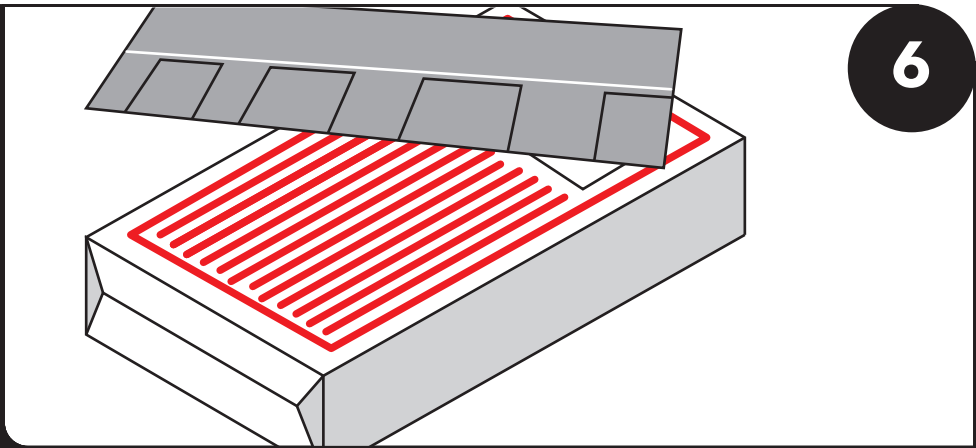

Work across then up. Continue to the top.

To cap the ridge, start the first capper centered on the ridge down past the corner.

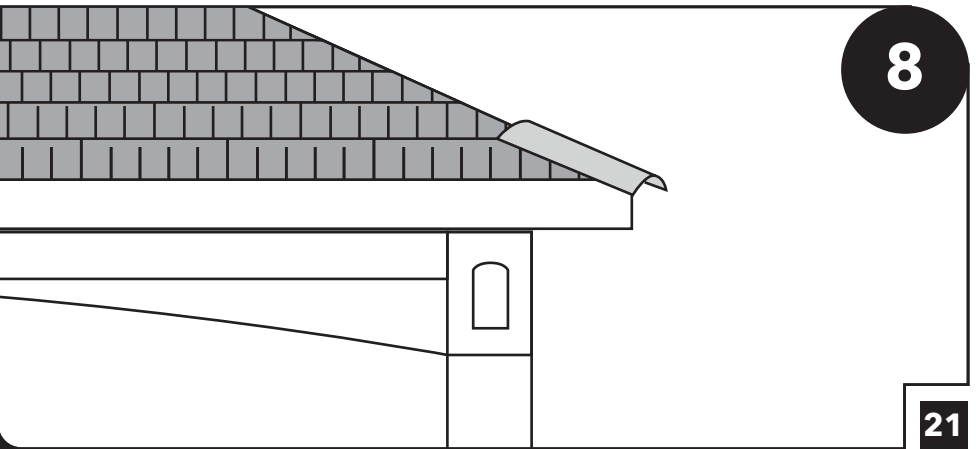

9

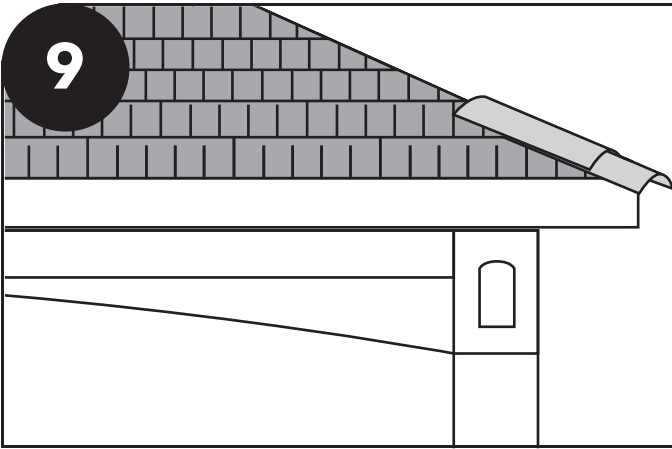

Place second capper into place.

Fasten using two 5/8" roof nails per capper. Fasten nail through the black tar strip.

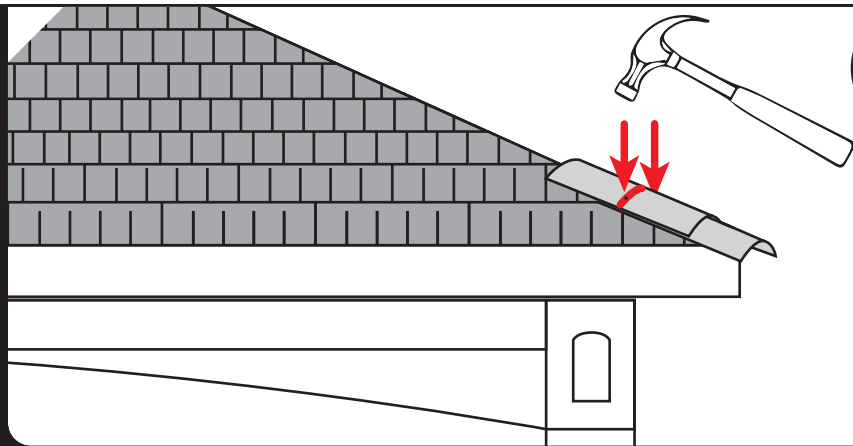

10

11

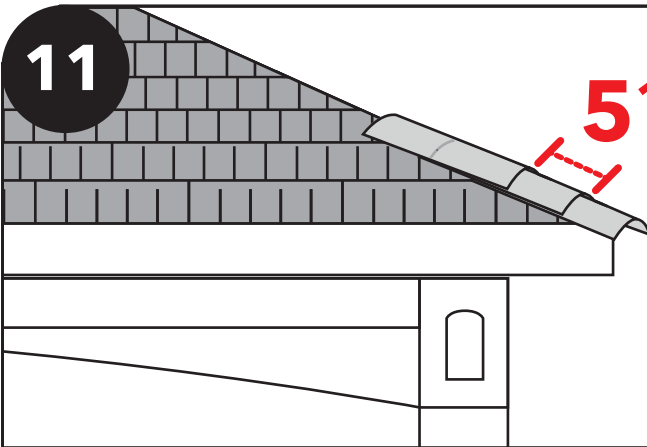

Leave approximately 5 1/2" exposed to the weather.

Continue up the ridge using the same previous steps. Install cappers in a nice straight row for a neat appearance from a ground view.

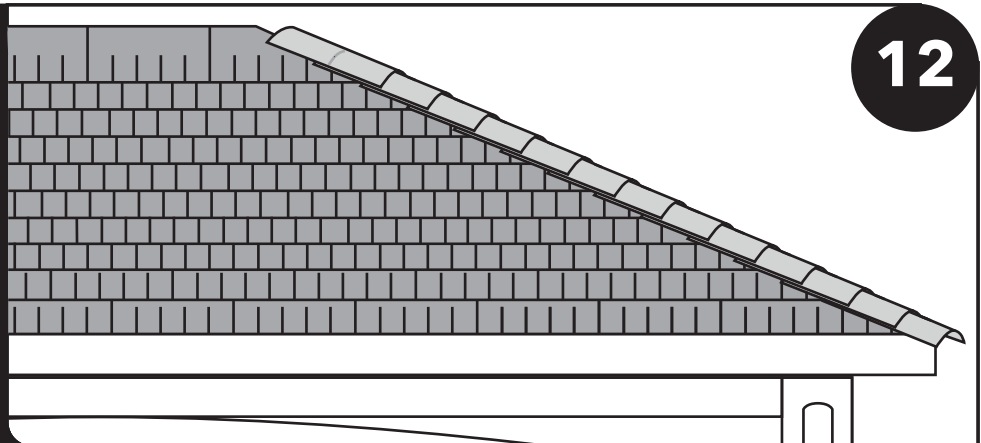

12

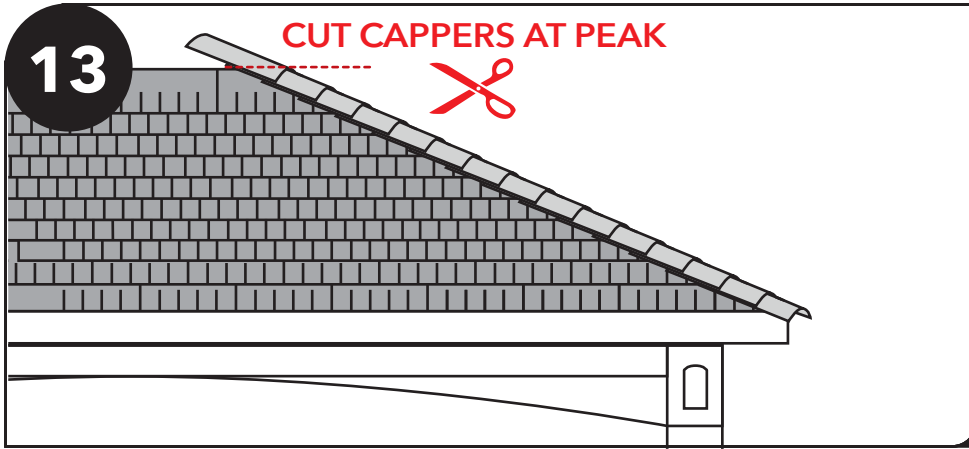

Trim the top.

Start at both ends of ridge and work toward the center of the ridge.

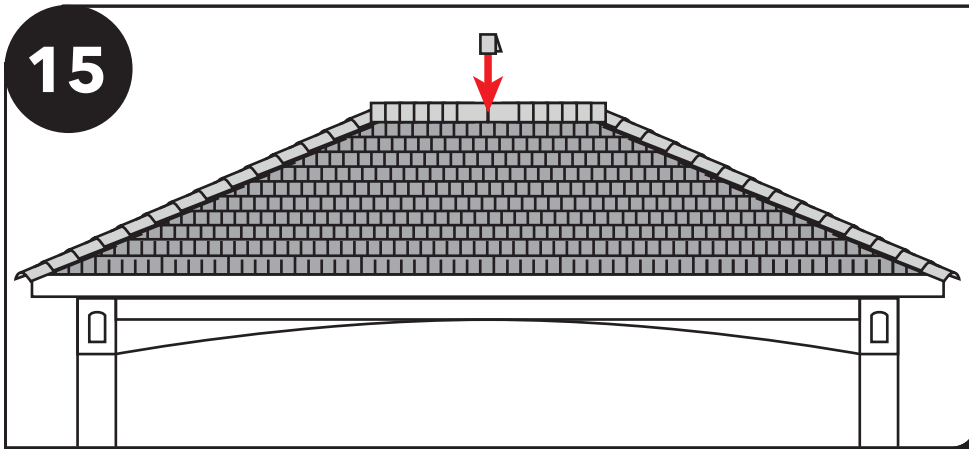
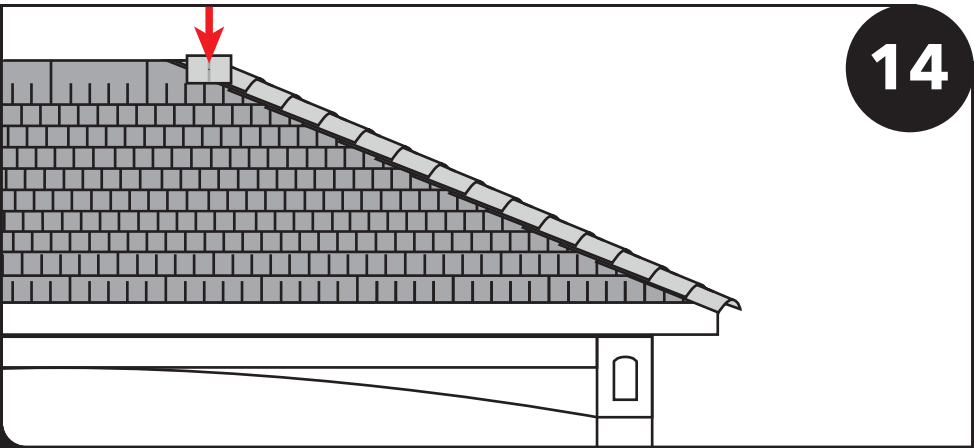

Last piece will need cut in half and will bring the corners together.

Trim the bottom edges using a shingle scissor or a utility knife.

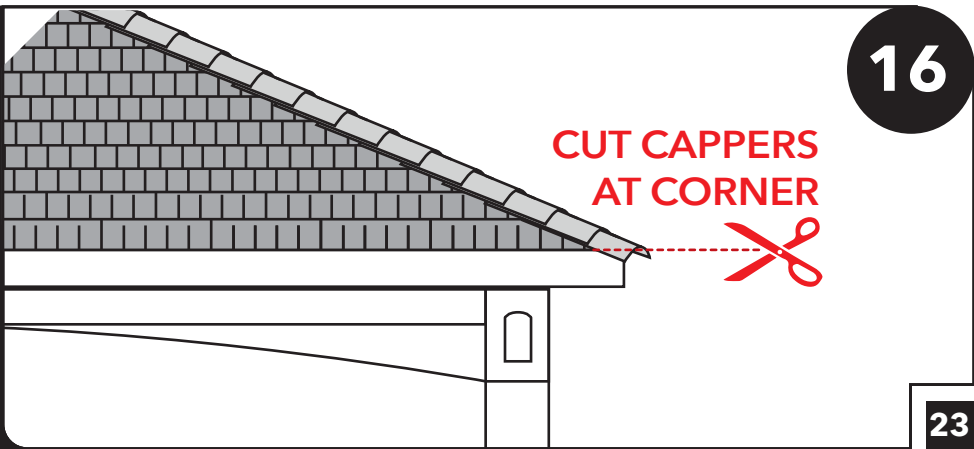

Ceiling Option 1: Installing An Interior Vinyl Ceiling

Install T Channel centered on ridge pole, using 3/4" nails, nailing every 16". Begin at ends and work inward.

Note: If you have a square pavilion, skip this step.

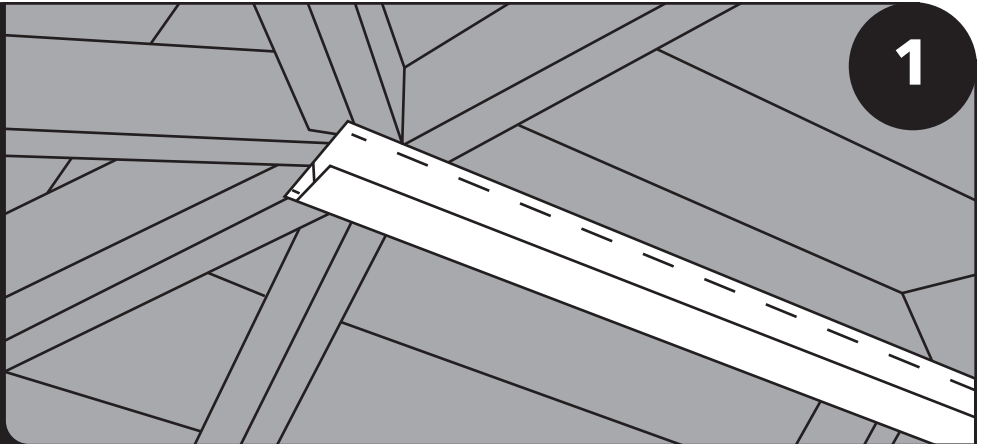

2

Install T Channel on hip rafters. Place lower end first, fitting the T Channel where hip rafter meets the plate.

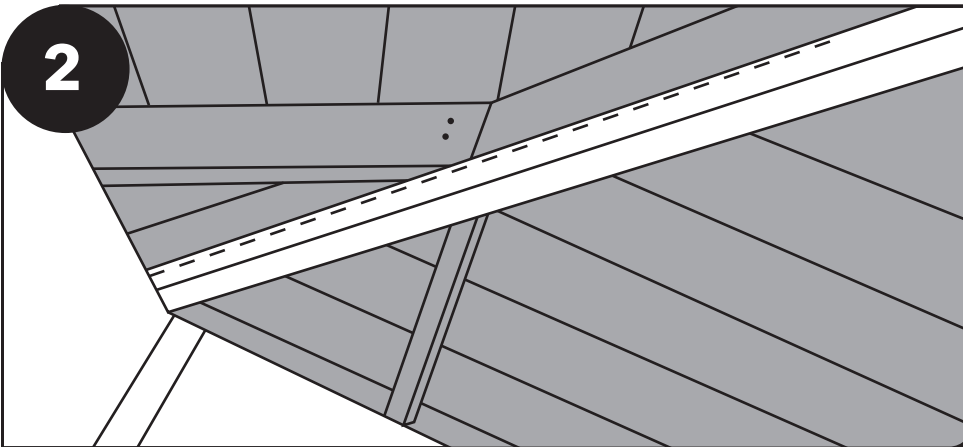

T Channel may be longer than space provided. Hold longer end against the ridge pole T Channel and mark appropriate angle then cut to size. Center on the hip rafter and fasten, using 3/4" nails, nailing every 16". Begin at the ends and work inward.

3

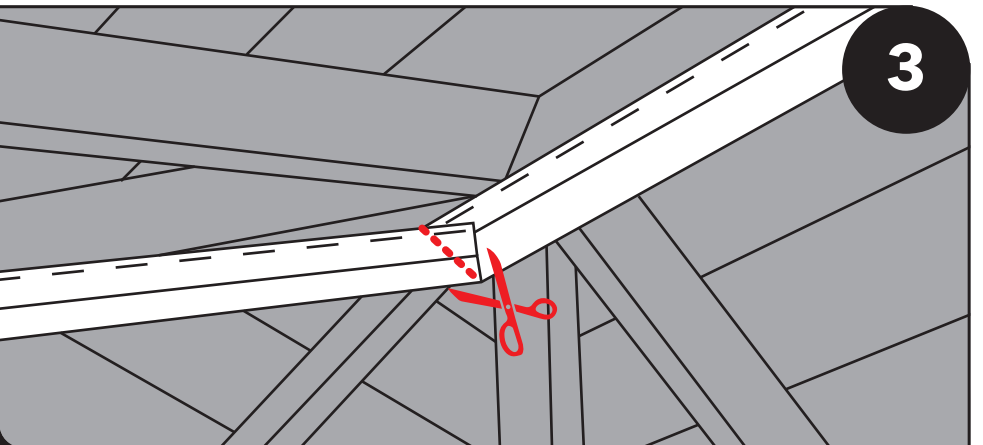

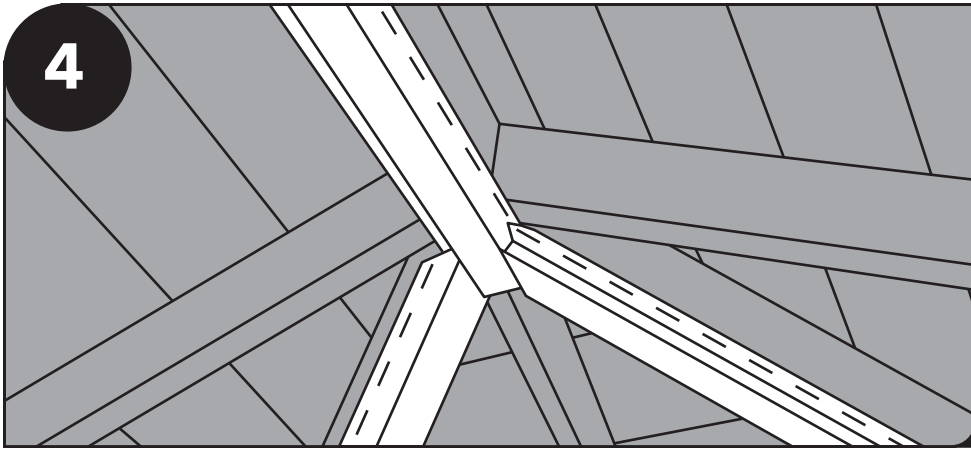

Complete Step 3 on all hip rafters.

Install first piece of vinyl ceiling. If piece is longer than provided space, mark appropriate angle and cut accordingly. Be sure to measure twice before cutting to reduce gaps. Nail 3/4" nails at each rafter. Interlock next piece and repeat last step working upward.

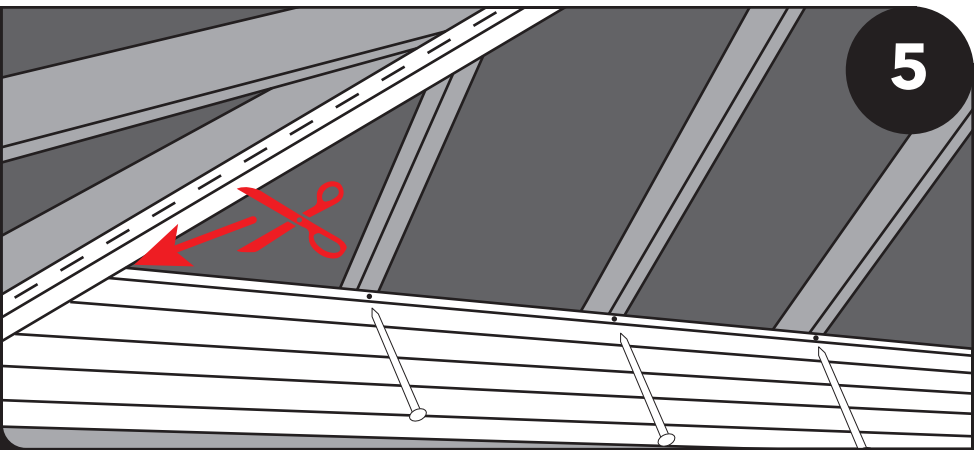

Ceiling Option 2: Installing An Interior Wood Ceiling

Locate the ceiling boards that are wrapped together. They will be wrapped in order--smallest to largest.

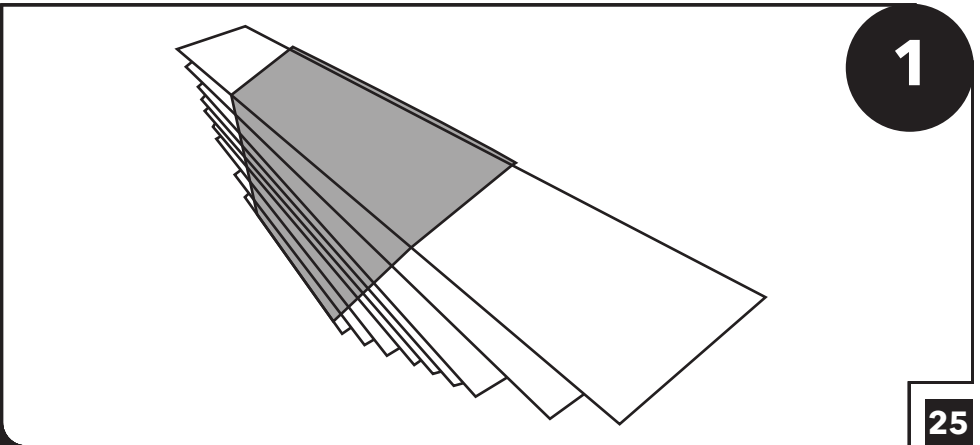

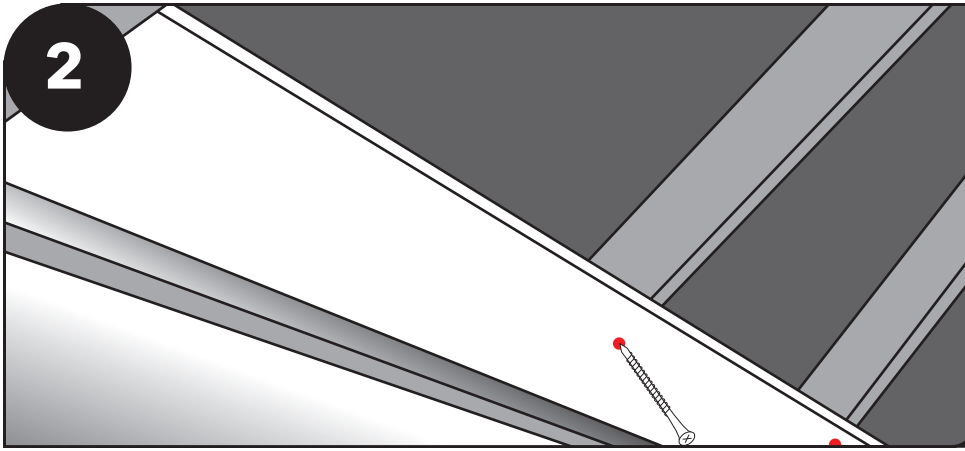

Using the largest piece start at the bottom and work upward. **Note: The first piece will have an angled side and a tongue side. Fasten the board with 1 1/2" screws at each rafter.**

Note: Be sure that the tongue of the board is facing upward, so the next board can connect to the last.

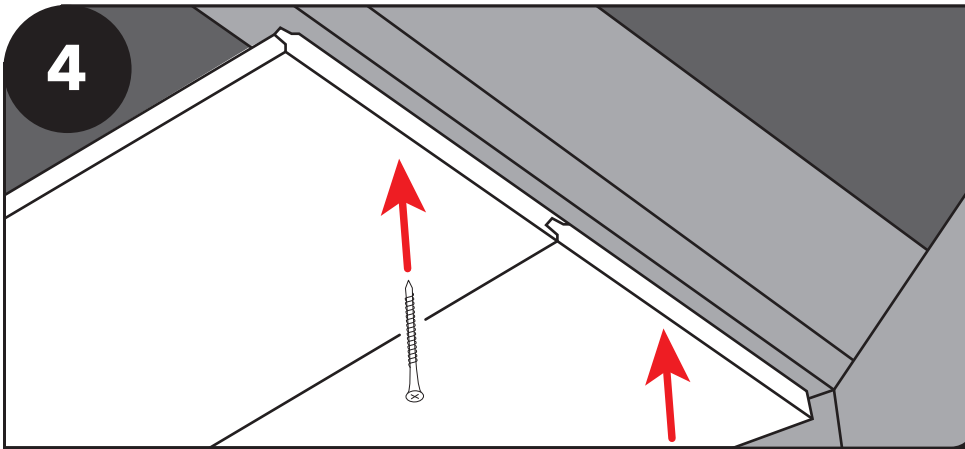
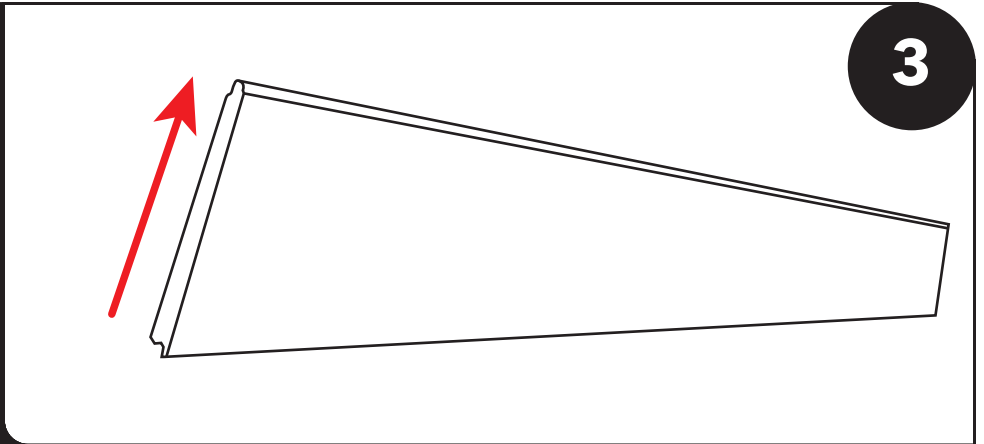

Place the groove of the next board into the tongue of the last board. Make sure boards are flush with no gaps before continuing on. Fasten board to each rafter.

Complete steps 2-4 for all sides of the pavilion for all but the last piece. Hold the last piece in place and mark where end needs to be cut. Then cut top pieces and screw them into place.

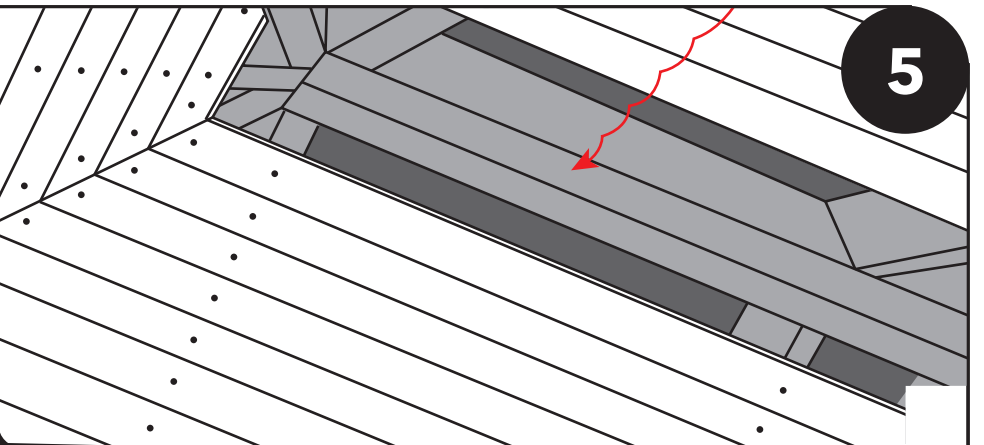

6



VIEW FROM INSIDE
PAVILION LOOKING UP

Next, install the four 1"x3" hip rafter trim pieces. Fasten with three 2 1/2" screws. Place one screw at the bottom, one in the middle, and one at the top.

You are now ready to install the 1"x3" ridge pole trim piece. Place a 2 1/2" screw at the end, middle, and other end.

7



VIEW FROM INSIDE
PAVILION LOOKING UP

8



VIEW FROM INSIDE
PAVILION LOOKING UP

Note: If you purchase a square pavilion, a square insert will be placed into the compression ring. The trimmed side will then be fastened to the ceiling with four 2 1/2" screws, one per side.

Heavy Duty Anchors for High Wind

After placing post bases on from step 9, slide HD high wind bracket onto the bottom of the post. Screw two 3/8"x3" hex lags into the pre-drilled holes on opposite sides of the bracket. Repeat on all posts. Continue on with regular instructions, starting at step 10.

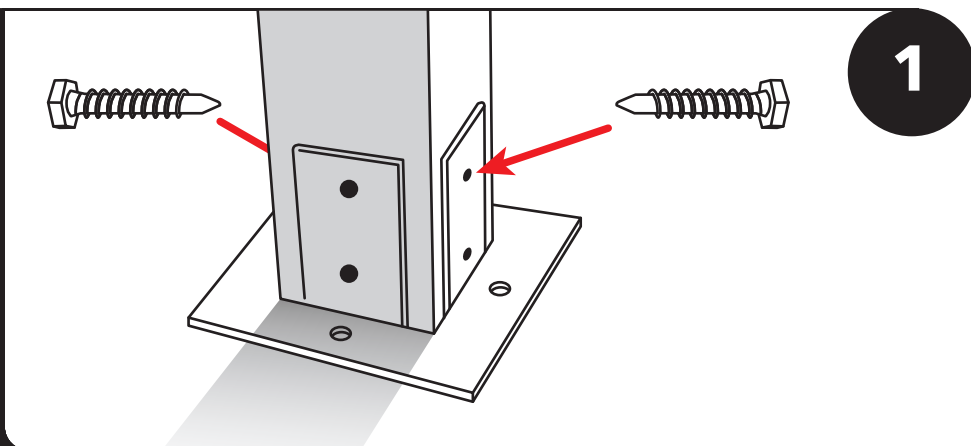

2

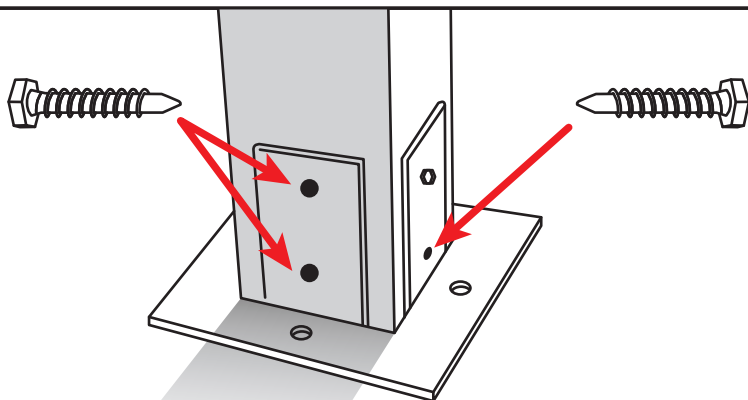

Screw the remaining six 3/8" X 3" hex lags into each post, using the pre-drilled holes. Repeat with all posts.

Remove dust from hole. Next, screw the nut and washer on about 1/8" below the top of the bolt. Insert the wedge anchor bolt into the hole. Tap the bolt into the ground using a piece of wood as a buffer to protect the threads and nut. Repeat on remaining 3 sides of the post then repeat on all other posts.

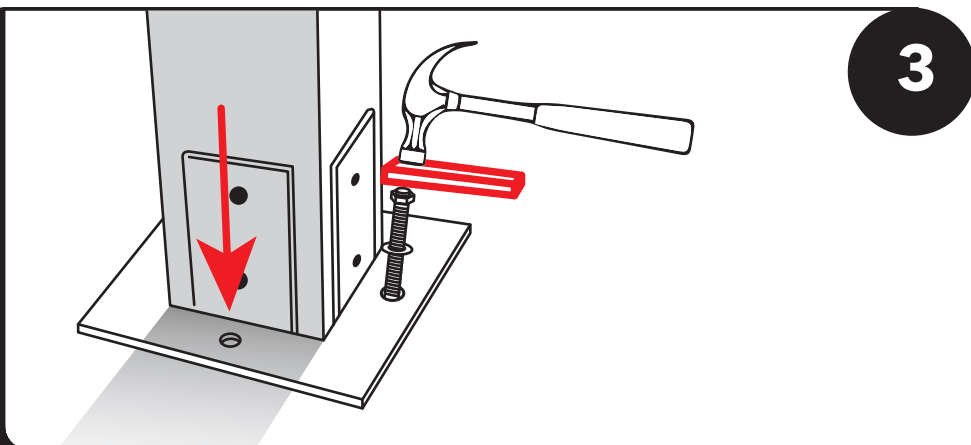

4

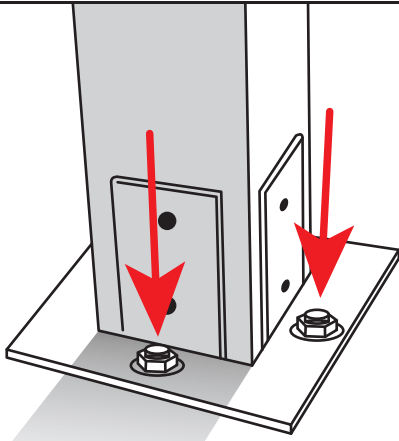

Continue on with regular instructions at page 7, step 19.

Square Pavilion Roof Construction

1

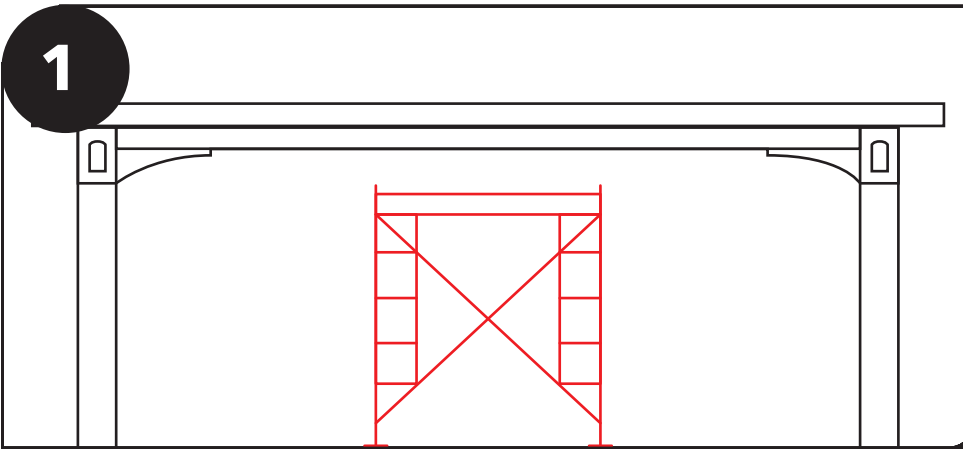

Build scaffolding in the center of the square stick built pavilion.

Locate compression Ring and place on the top of the scaffolding for later.

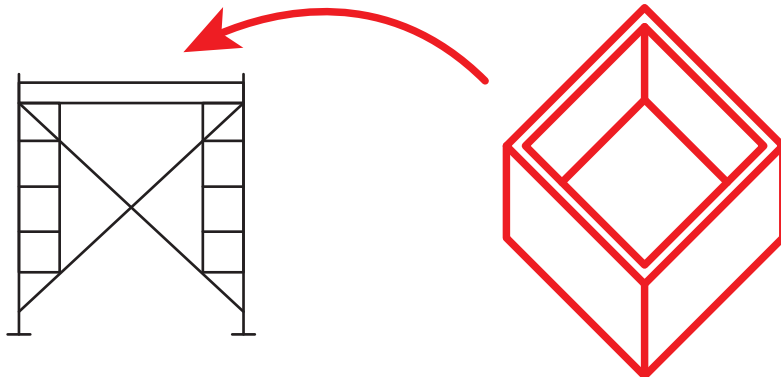

2

3

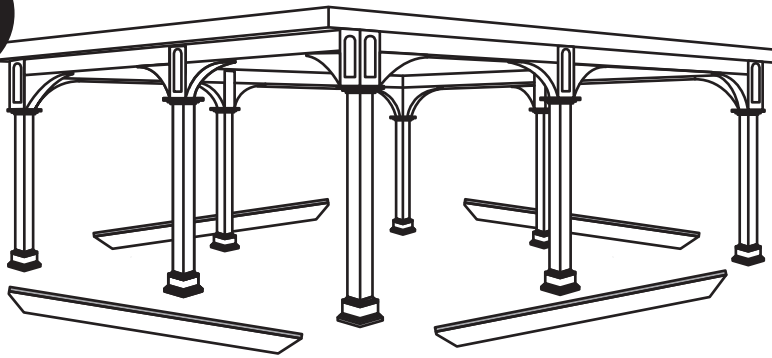

Locate the four rafters, marked "Center" and place one on each side of the pavilion for later.

Hold the compression ring at the needed height. Place a center rafter with the side marked "Center" against the compression ring. Be sure to line the center of the rafter up with the marked line and the pre-drilled holes of the compression ring. Also, be sure to keep the compression ring bottom edge and the rafter bottom edge flush with each other.

4

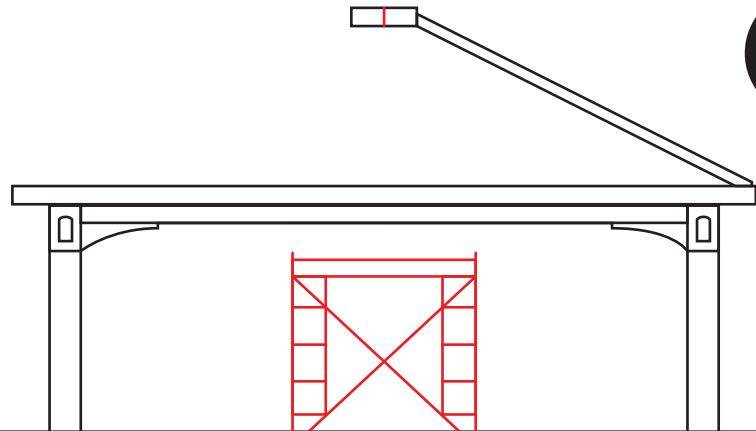

5

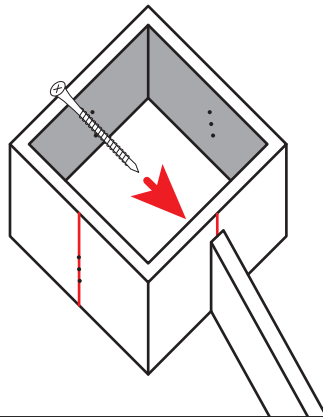

Once the rafter is properly flush. Screw the needed number of 3 1/2" screws into the pre-drilled holes.

Repeat steps 4-5 on all four sides. **NOTE: Be sure to support rafters and compression ring with workers or two prop boards until rafters are fastened to rafter plate.**

6

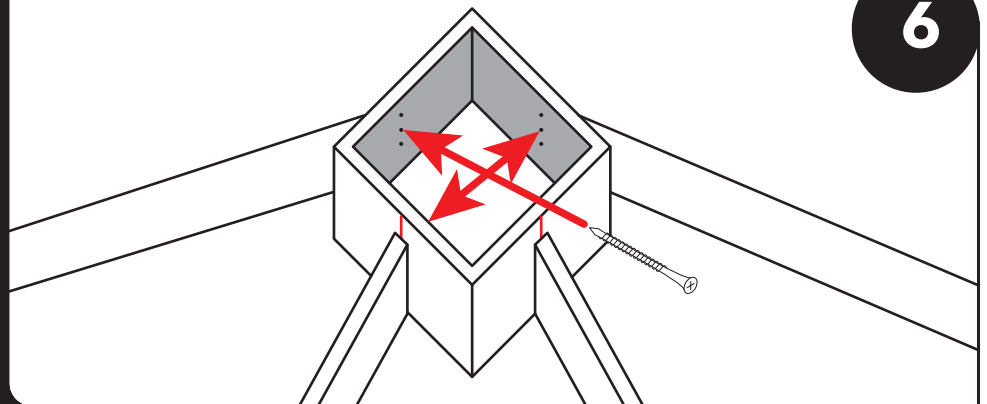

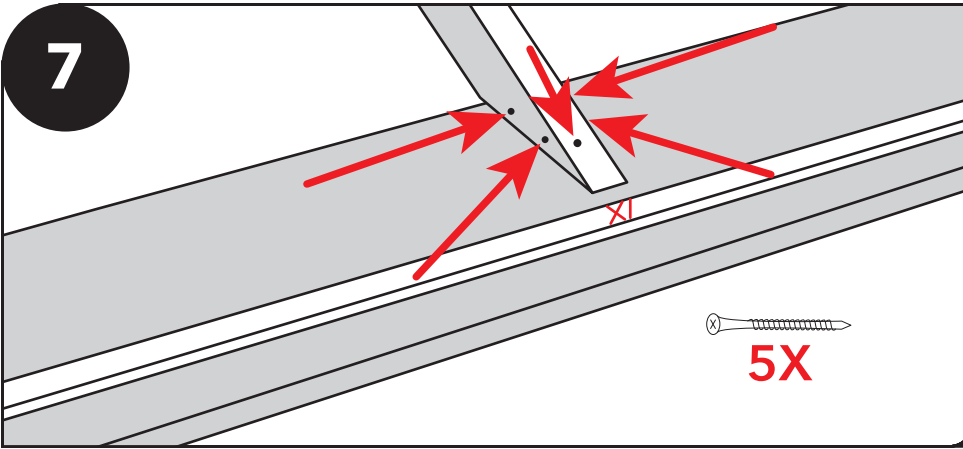
7

Fasten rafters centered on the marked line, located on the plate. Screw five 3 1/2" screws, two horizontally on each side and one on the top side of the rafter. Be sure to fasten each opposite side first. Do not work clockwise.

Locate four hip rafters, which are two boards screwed together. The ends with a 90 degree vertical notch go toward the compression ring.

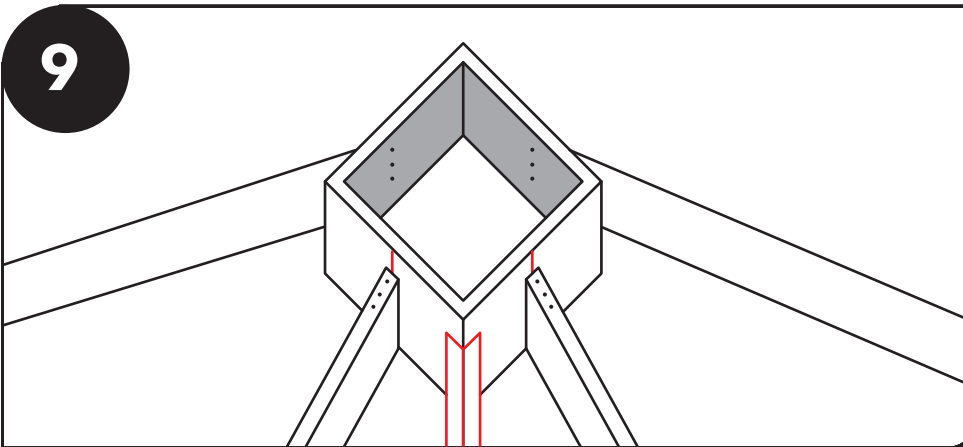
**8****9**

Place the 90 degree vertical notch against the corner of the compression ring. Be sure to keep the bottom edge of the hip rafter flush with the bottom edge of the compression ring. Screw 3 1/2" screws into each pre-drilled hole from the inside of the compression ring.

Repeat with all four hip rafters working clockwise.

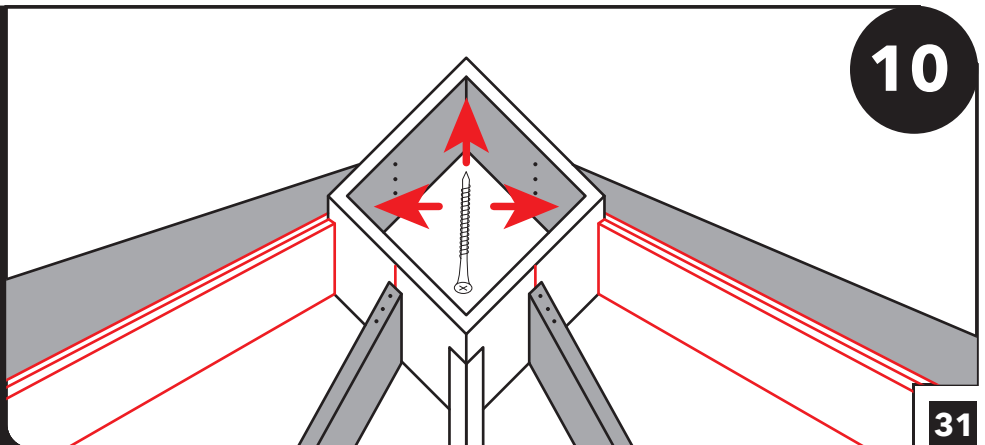
**10**

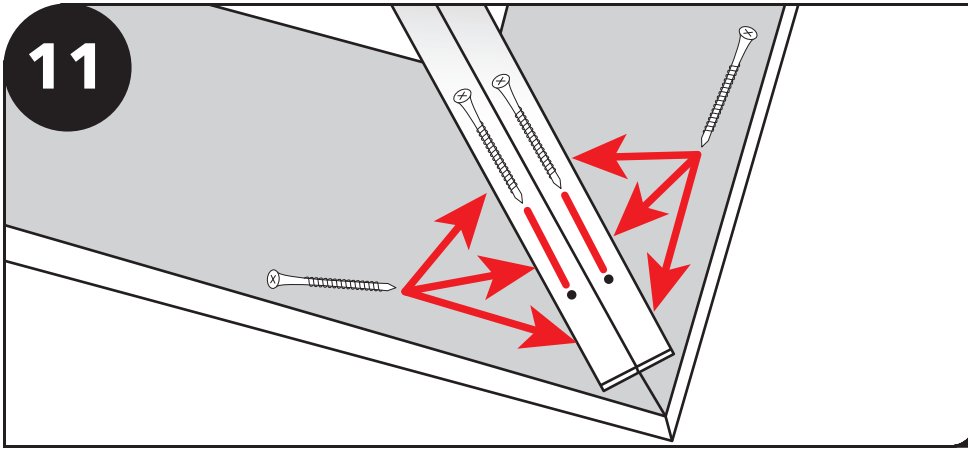

Fasten eight 3 1/2" screws into the hip rafter and plate. Three horizontally on each side and one per board on the top.

Identify your jack rafters. The jack rafters will have a bevel cut on the upper end.

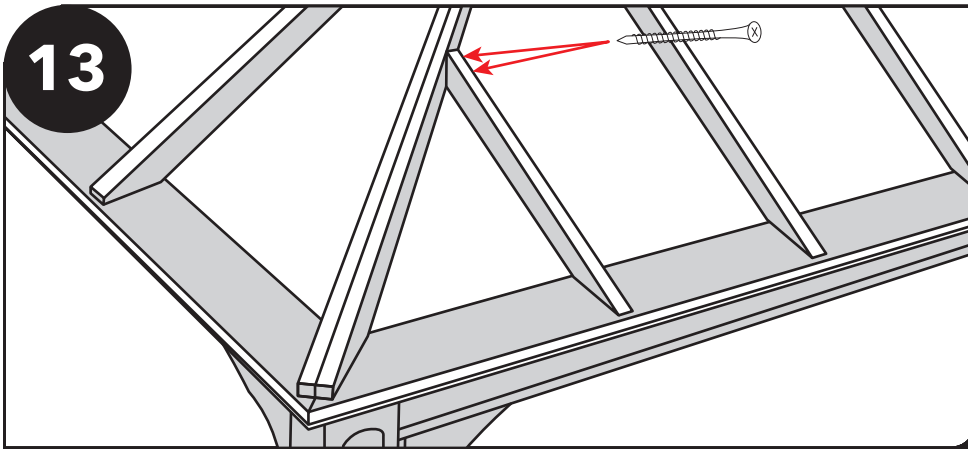
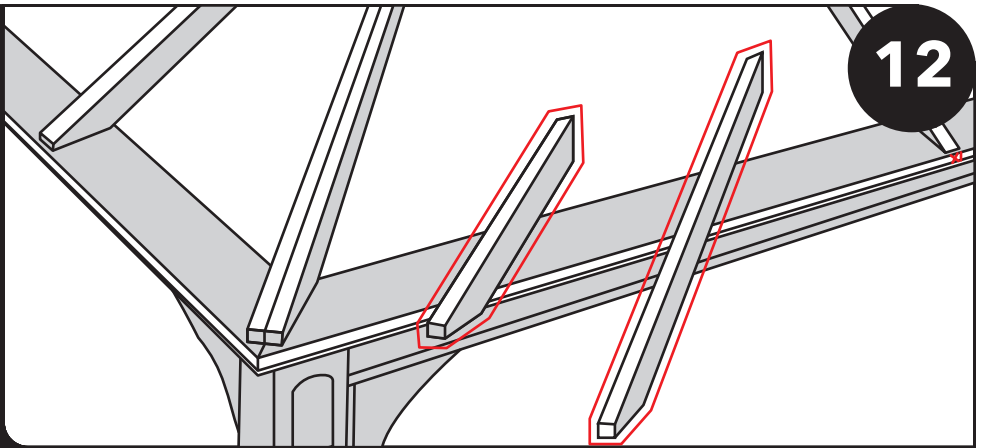

Jack rafters will only fit properly on left or right side based on upper bevel angle. Fasten correct jack rafter into the hip rafter with two 2 1/2" screws staying 1/4-1/2" in on the edge of the plate.

Measure from the top of the jack rafter to the side of the side rafter. Repeat the measurement on the lower end of the jack rafters before fastening to ensure equal distance at top and bottom.

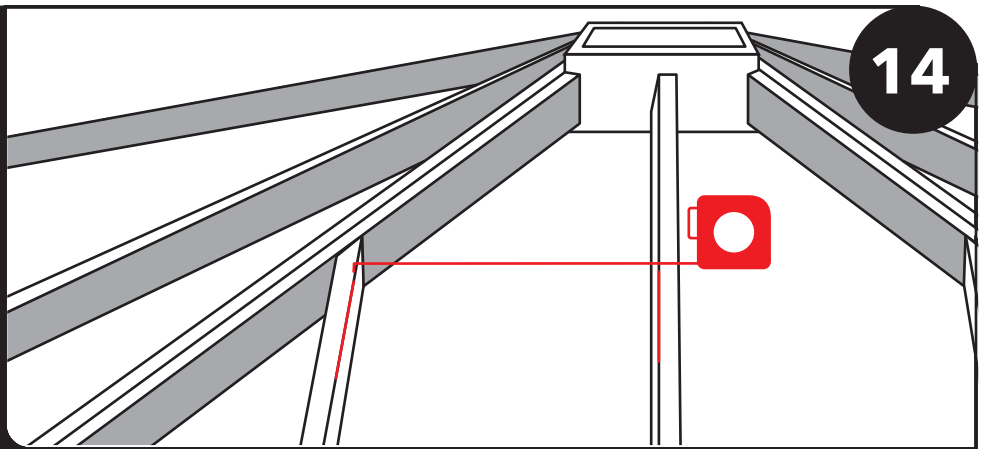

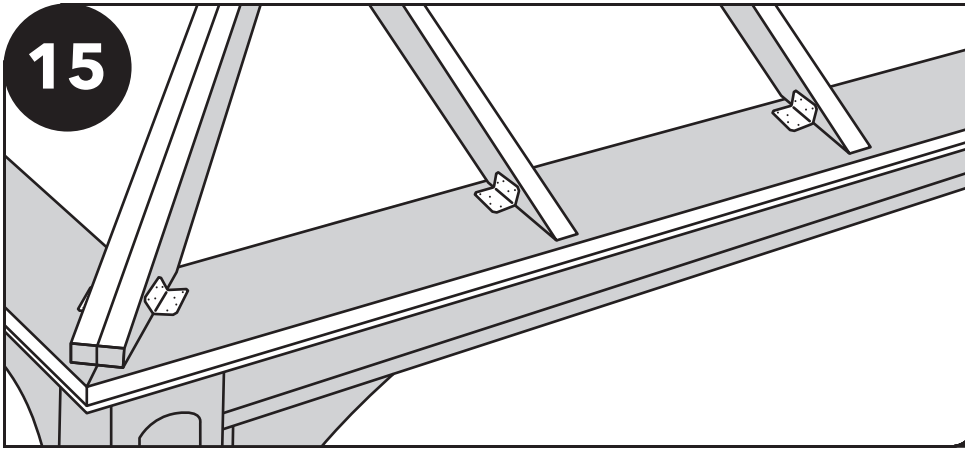

15
Fasten two 'A23 Simpson' brackets with 1 1/2" screws on either side of each corner hip rafter and one 'A23 Simpson' bracket at each side rafter and jack rafter.

16
Install the first piece of roof decking making sure not to extend past plate edge. Board may need to be cut to length. (At times decking may need to be spliced on a single rafter.) Fasten decking using two 2" nails per rafter.

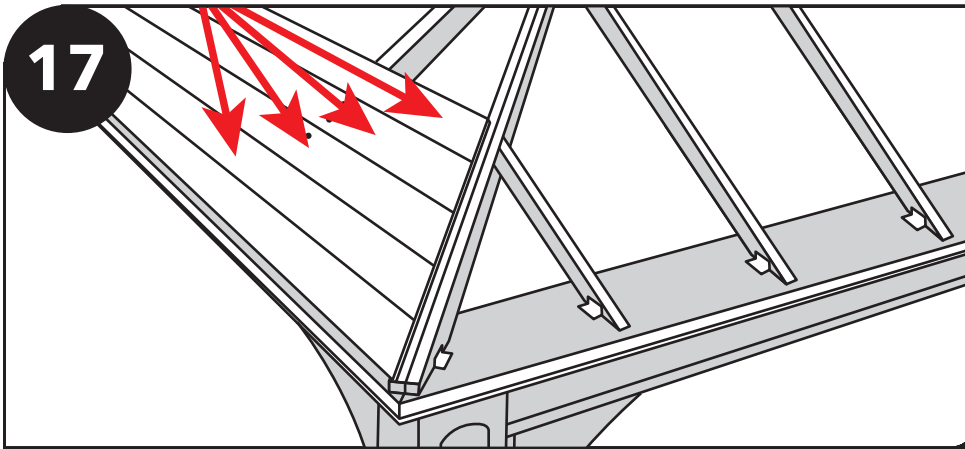
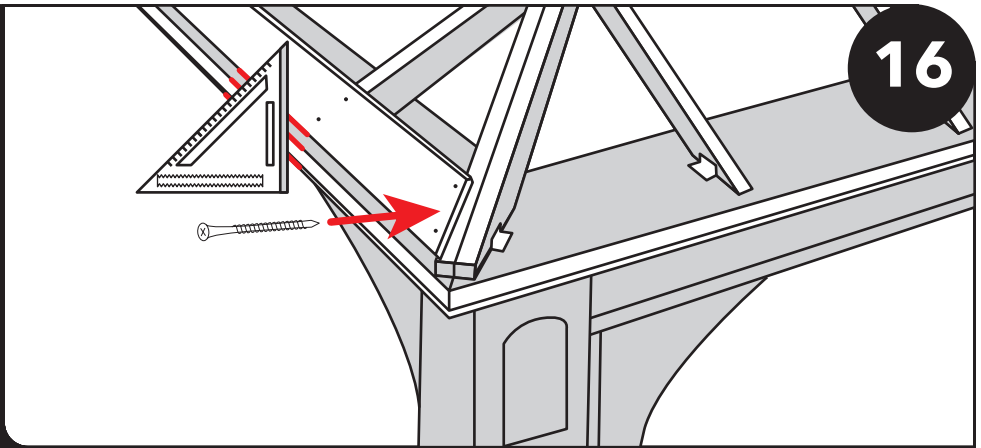

17
Securely interlock each piece of the roof decking, starting from the bottom and working up.

18
Repeat on all four sides.

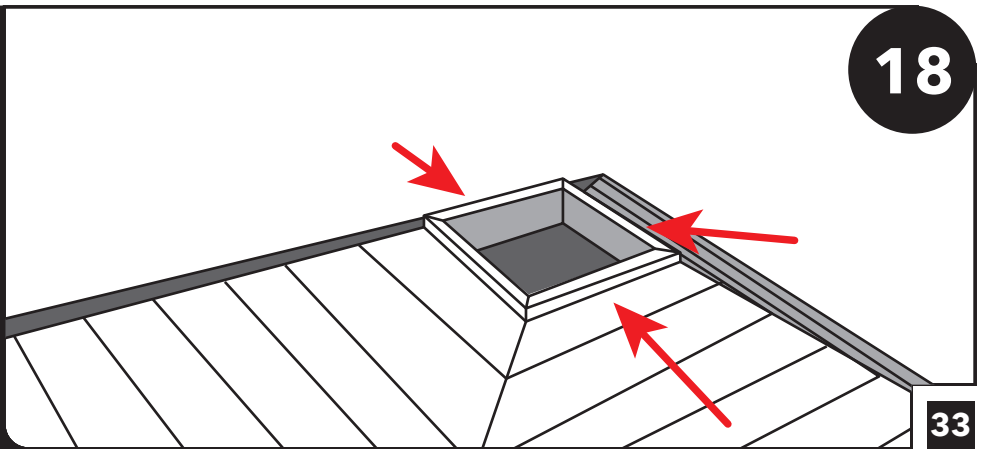

19

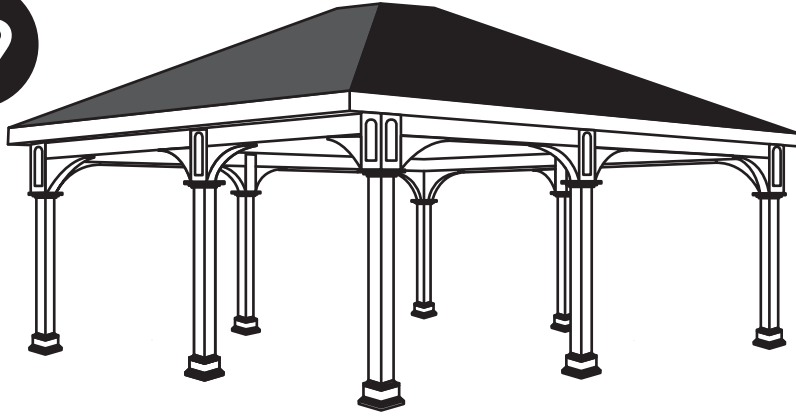

You are now ready to return to page 12, step 38.

